

FAN DRIVE GEAR MOTORS

Group 2 and Group 3 | Technical Information





History of revisions

Date	Page	Changed	Rev.
28, Jun 2010	-	First edition	A
16, Feb 2011	All	Covers color blue, brand name Turolla, copyright changes.	B
30, Sept 2013	All	Layout, options lists	C

Reference documents

System component	Title	Type and order number
Pump	Cast Iron Hydraulic Gear Pumps Series D	Technical Information L1022940
	Aluminium Gear Pumps Group 2	Technical Information L1016341
	Aluminium Gear Pumps Group 3	Technical Information L1016456
Valve	Proportional Solenoid Valves for Fan Drives Motors	Tech Note 11065482
Fan Drive control	Fan Drive Subsystem Application	11076673 • Rev BA • Apr 2010

© 2013 Turolla™. All rights reserved.

Turolla accepts no responsibility for possible errors in catalogs, brochures and other printed material. Turolla reserves the right to alter its products without prior notice. This also applies to products already ordered provided that such alterations can be made without affecting agreed specifications. All trademarks in this material are properties of their respective owners. Danfoss, Turolla, Turolla OpenCircuitGear, OpenCircuitGear, Fast Lane and PLUS+1 are trademarks of the Danfoss Group.



Index

General Information

- 5 Overview
- 6 Features and benefits
- 7 Fan drive motor displacements
- 8 Determination of nominal motor sizes
- 9 Fan drive motor circuit illustrations

System Requirements

- 10 Pressure
- 11 Speed
- 11 Hydraulic fluids
- 12 Temperature and viscosity
- 13 Filtration
- 13 Filters
- 13 Selecting a filter
- 13 Reservoir
- 14 Line sizing
- 14 Motor shaft connection
- 14 Motor life

Group 2 Fan Drive Gear Motors – SGM2NC

- 15 Motor design
- 15 Technical data
- 16 Model code
- 19 Mounting flange and shaft options
- 20 SGM2NC • 02AA dimensions
- 22 SGM2NC • 06BA dimensions
- 24 SGM2NC • 06GB dimensions

Group 2 Fan Drive Gear Motors – SGM2YN

- 26 Motor design
- 26 Technical data
- 28 Model code
- 33 Mounting flange and shaft options
- 34 SGM2YN • 02AA dimensions
- 36 SGM2YN • 06BA dimensions
- 38 SGM2YN • 06GB dimensions

Group 2 Fan Drive Gear Motors – SGM2VC

- 40 Motor design
- 40 Technical data
- 42 Model code
- 45 Mounting flange and shaft options
- 46 SGM2VC • 02AA dimensions
- 48 SGM2VC • 06BA dimensions
- 50 SGM2VC • 06GB dimensions
- 52 Outrigger bearing



Group 3 Fan Drive Gear Motors – SGM3NC

- 53 Motor design
- 53 Technical data
- 54 Model code
- 57 Mounting flange and shaft options
- 58 SGM3NC • 07BC dimensions
- 60 SGM3NC • 07GB dimensions

Group 3 Fan Drive Gear Motors – SGM3YN

- 62 Motor design
- 62 Technical data
- 64 Model code
- 68 SGM3YN • 07BC dimensions
- 70 SGM3YN • 07GB dimensions

Group 3 Fan Drive Gear Motors – SGM3VC

- 72 Motor design
- 72 Technical data
- 74 Model code
- 78 SGM3VC • 07BC dimensions
- 80 SGM3VC • 07GB dimensions
- 82 Outrigger bearing



General information

Overview

Turolla has over many years built up a wealth of experience with its hydraulic and electro-hydraulic fan drive systems for vehicles and machines operating both on and off highway. Modern fan drives require proportional electronic control to meet new emissions legislation. SGM2 and SGM3 fan drive motors are based on the proven high performance Turolla gear motors.

A proportional pressure relief valve with pilot operated spool (normally closed) is integrated in the cast-iron rear cover of the motor. A gear pump supplies oil to the fan drive motor. The PWM signal to the solenoid pressure relief valve controls the oil flow through the motor which determines the fan speed. The fan speed is controlled to maintain optimum engine and hydraulic system temperatures. The SGM2YN, SGM3YN, SGM2VC and SGM3VC provide this proportional control in an integrated package within the rear cover.

Bi-directional fan motor capability is necessary when it is desired to switch the rotation of the fan blade for such reasons as cleaning debris from a radiator. This allows for more efficient cooling of the machine engine and functions. The SGM2NC and SGM3NC provide the bidirectional capability for use with remote, inline mounted HIC manifolds that provide the reversing flow. The SGM2VC and the SGM3VC integrate the reversing valve capability in the rear cover of the motor.

Due to the versatility, flexibility and reliability of Turolla fan drive systems, they may be applied in numerous applications, such as:

- Agriculture machinery
- Construction machinery
- Material handling vehicles
- Road building vehicles
- Forestry machinery
- On-Highway vehicles





Features and benefits

- Two groups of frame size (Group 2 and 3)
- Steel and cast iron rear covers for 250 bar (3626 psi) continuous performance and 270 bar [3916 psi] peak pressure for all port configurations
- Displacement from 8 to 44 cm³/rev [from 0.51 to 2.69 in³/rev]
- Maximum speed 3500 rpm for Group 2 and 2500 rpm for Group 3
- Extreme temperature seals for continuous operation from -20 °C [-4 °F] up to +95 °C [+203 °F], for today's more demanding applications.
- Two electro-hydraulic proportional valve options: PRV for standard fan speed modulation and optional flat curve valves for such applications as fan motors in series.
- Deutch Electrical connectors as standard to withstand dust and debris in the environment.
- 12 V DC and 24 V DC coils.
- Fail safe function - full fan speed if electrical signal fails.
- Pressure settings factory pre-set for individual system performance.
- High efficiency gear motors to reduce system losses and retain useful hydraulic power work functions
- Outrigger bearings available for all 3 models to provide increased bearing capacity and therefore more durability or extended life in applications such as slewing, tracked machines, vibe and shock load applications that possess gyroscopic and impact loads or heavy steal fan blades.
- Shaft seal dust protector standard on all models for extended seal life in fan drive applications
- 2 Anti-Cavitation High Pressure Shock Valves, to clip pressure spikes in both directions of motor rotation, while reversing, where the competition uses only 1.
- Integrated Reversing Directional Control Valves with open spool transitions to reduce system pressure spikes.
- High performance valves and the use of steel / cast iron allows for full system pressure capability without de-rating the SGM product during reversing or proportional control.
- Feature for Feature industry leading short package to preserve much needed engine space: integrated valves packages and factory sealed outrigger bearings with high speed capability,
- PLUS+1 Compliant electronic interface allows for integration with PLUS+1 microcontrollers and other compliant products including sensors and graphical displays.



Fan drive motor displacements

Quick reference chart for fan drive motor models

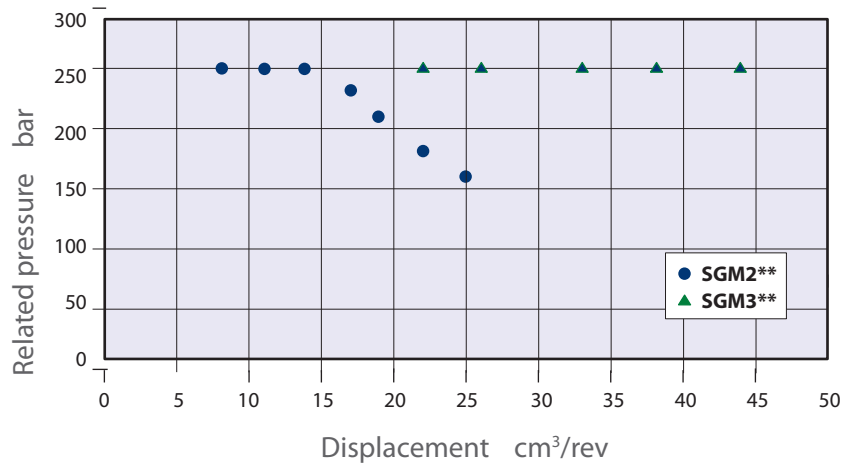



Determination of nominal motor sizes

Use these formulas to determine the nominal motor size for a specific application.

Based on SI units

Input flow: $Q = \frac{V_g \cdot n}{1000 \cdot \eta_v}$ l/min

Output torque: $M = \frac{V_g \cdot \Delta p \cdot \eta_m}{20 \cdot \pi}$ N·m

Output power: $P = \frac{M \cdot n}{9550} = \frac{Q \cdot \Delta p \cdot \eta_t}{600}$ kW

Based on US units

$Q = \frac{V_g \cdot n}{231 \cdot \eta_v}$ [US gal/min]

$M = \frac{V_g \cdot \Delta p \cdot \eta_m}{2 \cdot \pi}$ [lbf·in]

$P = \frac{M \cdot n}{63\,025} = \frac{Q \cdot \Delta p \cdot \eta_t}{1714}$ [hp]

Variables SI units [US units]

V_g	= Displacement per revolution	cm ³ /rev [in ³ /rev]
p_o	= Outlet pressure	bar [psi]
p_i	= Inlet pressure	bar [psi]
Δp	= $p_o - p_i$ (system pressure)	bar [psi]
n	= Speed	min ⁻¹ (rpm)
η_v	= Volumetric efficiency	
η_m	= Mechanical efficiency	
η_t	= Overall efficiency ($\eta_v \cdot \eta_m$)	



Fan drive motor circuit illustrations

Gear pump/gear motor with HIC electrical control

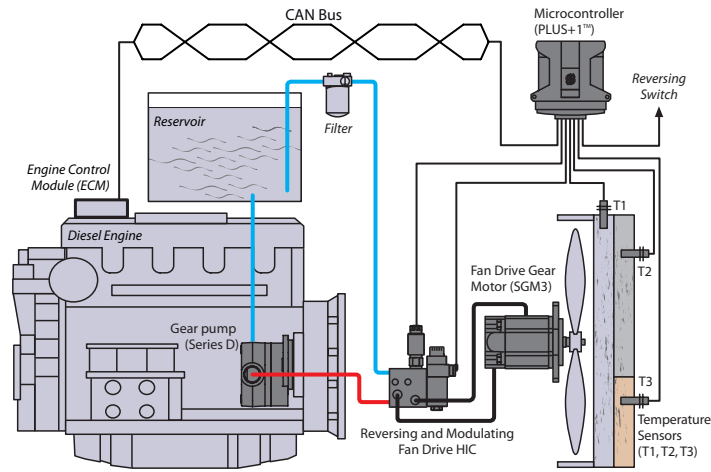

Gear pump/gear motor with electro-proportional relief valve

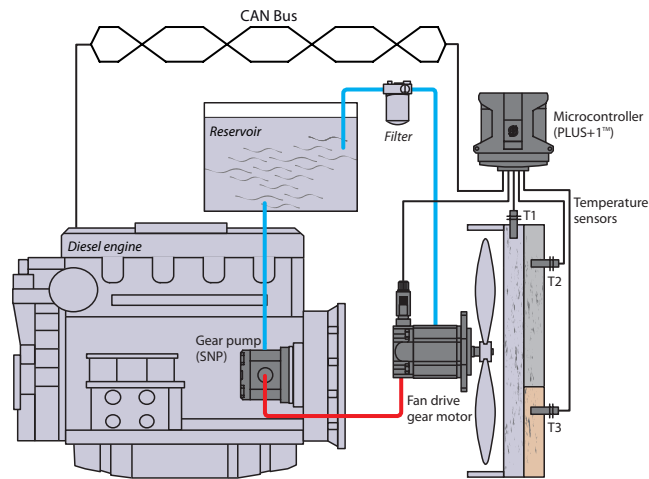

Gear pump/gear motor with integrated reversing control valve

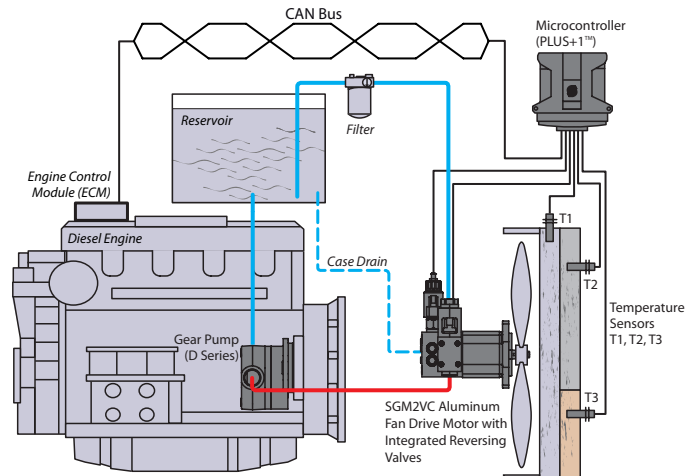



System requirements

Pressure

Peak pressure is the highest intermittent pressure allowed. The relief valve overshoot (reaction time) determines peak pressure. It is assumed to occur for less than 100 ms.

The illustration to the right shows peak pressure in relation to rated pressure and reaction time (100 ms maximum).

Rated pressure is the average, regularly occurring operating inlet pressure that should yield satisfactory product life. The maximum machine load at the motor shaft determines rated pressure.

Time versus pressure

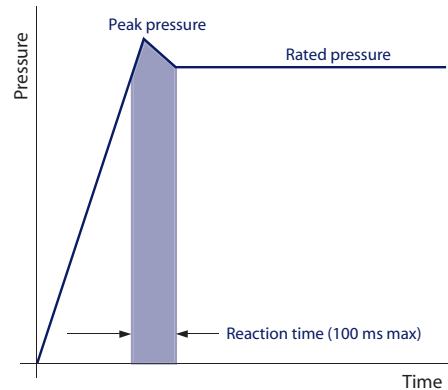

System pressure is the differential between the inlet and outlet ports. It is a dominant operating variable affecting hydraulic unit life. High system pressure, resulting from high load at the motor shaft, reduces expected life. System pressure must remain at, or below, rated pressure during normal operation to achieve expected life.

Back pressure is the average, regularly occurring operating outlet pressure that should yield satisfactory motor life. The hydraulic load demand downstream of the motor determines the back pressure. The fan drive gear motor can work with back pressure and the maximum back pressure allowed is 60% of the maximum rated pressure.

Case drain pressure is the regularly occurring case drain line pressure that should yield satisfactory motor life. It is recommended to design the case drain piping connecting the case drain direct to the tank in order to keep the case drain pressure as low as possible. Max. continuous case drain pressure allowed is 5 bar [72.5 psi] with a peak of 7 bar [101.5 psi].



Speed

Speed

Maximum speed is the limit recommended by Turolla for a particular gear motor when operating at rated pressure. It is the highest speed at which normal life can be expected. N_2 is max speed related to the RV valve setting (p_2) and type of fan.

The lower limit of operating speed is the **minimum speed**. It is the lowest speed at low pressure.

The minimum speed increases as operating system pressure increases. When operating under higher pressures, a higher minimum speed must be maintained, as illustrated to the right.

Speed versus pressure

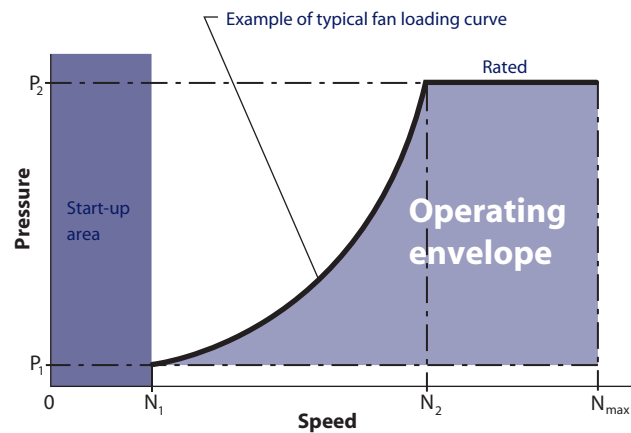

Hydraulic fluids

Ratings and data for gear motors are based on operating with premium hydraulic fluids containing oxidation, rust, and foam inhibitors. These fluids must possess good thermal and hydrolytic stability to prevent wear, erosion, and corrosion of internal components.

Please see Turolla publication [Hydraulic Fluids and Lubricants Technical Information, L1021414](#) for more information. Use only clean fluid in the motor and hydraulic circuit.

⚠ Caution

Never mix hydraulic fluids.



Temperature and viscosity

Temperature and viscosity requirements must be concurrently satisfied.
Use petroleum/mineral-based fluids.

Temperature

High temperature limits apply at the inlet port of the motor. The motor should run at or below the maximum continuous temperature.

Cold oil, generally, doesn't affect the durability of motor components. It may affect the ability of oil to flow and transmit power. For this reason, keep the temperature at 16°C [60 °F] above the pour point of the hydraulic fluid.

Minimum (cold start) temperature

relates to the physical properties of component materials.

Maximum continuous temperature

allowed at which normal life can be expected.

Temperature

Minimum (cold start)	°C [°F]	-20 [-4]
Maximum continuous		95 [203]
Peak (intermittent)		110 [230]

Peak (intermittent) temperature: the overheating temperature that is tolerable by the machine for a transient/limited time.

Viscosity

Minimum viscosity occurs only during brief occasions of maximum ambient temperature and severe duty cycle operation. It's the minimum acceptable viscosity to allow normal motor life.

Maximum viscosity occurs only during cold start at very low ambient temperatures. It's the upper limit of viscosity that allows the motor to start.

Fluid viscosity

Maximum (cold start)	mm ² /s [SUS]	1600 [7273]
Recommended range		12–100 [66–456]
Minimum		10 [60]
Recommended range for high efficiency		20–50 [97–231]



Filtration

Filters

Use a filter that conforms to Class 22/18/13 of ISO 4406 (or better). It may be on the motor outlet (discharge filtration) or inlet (pressure filtration).

Selecting a filter

When selecting a filter, please consider:

- contaminant ingress rate (determined by factors such as the number of actuators used in the system)
- generation of contaminants in the system
- required fluid cleanliness
- desired maintenance interval
- filtration requirements of other system components

Measure filter efficiency with a Beta ratio (β_x):

- for discharge filtration with controlled reservoir ingress, use a $\beta_{35-45} = 75$ filter
- for pressure filtration, use a filtration with an efficiency of $\beta_{10} = 75$

β_x ratio is a measure of filter efficiency defined by ISO 4572. It is the ratio of the number of particles greater than a given diameter ("X" in microns) upstream of the filter to the number of these particles downstream of the filter.

Fluid cleanliness level and β_x ratio

Fluid cleanliness level (per ISO 4406)	Class 22/18/13 or better
β_x ratio (discharge filtration)	$\beta_{35-45} = 75$ and $\beta_{10} = 2$
β_x ratio (pressure filtration)	$\beta_{10} = 75$
Recommended inlet screen size	100 – 125 μm [0.0039 – 0.0049 in]

The filtration requirements for each system are unique. Evaluate filtration system capacity by monitoring and testing prototypes.

Reservoir

The **reservoir** provides clean fluid, dissipates heat, removes entrained air, and allows for fluid volume changes associated with fluid expansion and during all system operating modes. A correctly sized reservoir accommodates maximum volume changes during all system operating modes. It promotes de-aeration of the fluid as it passes through, and accommodates a fluid dwell-time between 60 and 180 seconds, allowing entrained air to escape.

Minimum reservoir capacity depends on the volume required to cool and hold the oil, allowing for expansion due to temperature changes. A fluid volume of one to three times the motor output flow (per minute) is satisfactory. The minimum recommended reservoir capacity is 125% of the fluid volume.

Put the return-line below the lowest expected fluid level to allow discharge into the reservoir for maximum dwell and efficient de-aeration. A baffle (or baffles) between the return and suction lines promotes de-aeration and reduces fluid surges.



Line sizing

Choose pipe sizes that accommodate minimum fluid velocity to reduce system noise, pressure drops and overheating in order to maximize system life and performance. Line velocity should not exceed 5.0 m/s [16.4 ft/s]:

Most systems use hydraulic oil containing 10% dissolved air by volume. **Over-aeration**, or entrained air, is the result of flow line restrictions, where the dissolved air comes out of solution, or when air is allowed to leak into the hydraulic circuit. These include inadequate pipe sizes, sharp bends, or elbow fittings, causing a reduction of flow-line cross-sectional area. This problem will not occur if these circuit recommendations are followed, rated speed requirements are maintained, and reservoir size and location are adequate.

Motor shaft connection

Shaft options for fan drive gear motors include tapered (1:5 and 1:8) and parallel.

Allowable **radial shaft loads** are a function of the load position, load orientation, and operating pressure of the hydraulic motor. All external shaft loads have an effect on bearing life, and may affect motor performance.

In applications where the external shaft loads cannot be avoided, minimize the impact on the motor by optimizing the orientation and the magnitude of the load. Turolla fan drive gear motors are capable of carrying most manufacturer's plastic fans up to 7.27 kg (16 lb) fan blades for the Group 2 and 11.75 kg (26 lb) fan blades for the Group 3.

For fan drives exceeding these loads, with presence of shock loads, or for slewing (swing) and oscillating applications such as Excavators, Wheel Loaders, Harvester, and Windrowers, please consult your Turolla Technical Representative for the potential usage of an outrigger bearing. See following drawing for fan drive mounting orientation to be considered.

Motor life is a function of speed, system pressure, and other system parameters (such as fluid quality and cleanliness).

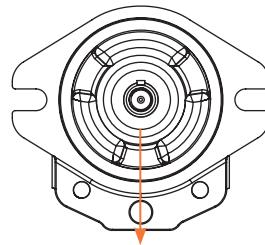

Motor life

All Turolla gear motors use hydrodynamic journal bearings that have

an oil film maintained between the gear/shaft and bearing surfaces at all times. If the oil film is sufficiently sustained through proper system maintenance and operating within recommended limits, long life can be expected.

B₁₀ life expectancy number is generally associated with rolling element bearings. It does not exist for hydrodynamic bearings.

High pressure impacts motor life. When submitting an application for review, provide machine duty cycle data that includes percentages of time at various loads and speeds. We strongly recommend a prototype testing program to verify operating parameters and their impact on life expectancy before finalizing any system design.



GROUP 2 FAN DRIVE GEAR MOTORS

SGM2NC

Motor design

SGM2NC is Group 2 bidirectional fan drive motor with inlet/outlet on cast iron rear cover and axial drain line

Displacement range from 8.4 cm³/rev up to 25.2 cm³/rev [from 0.51 up to 1.54 in³/rev].

Configurations include European and SAE flanges; taper 1:8, taper 1:5 and parallel Ø15.875 mm [Dia 0,62 in] shafts.

Outrigger bearing available as SAE A flange with taper shaft 1:8 and European flange with taper shaft 1:5.

SGM2NC



Technical data

Technical data for SGM2NC standard fan drive gear motors

Frame size		8,0	011	014	017	019	022	025
Displacement	cm ³ /rev	8.4	10.8	14.4	16.8	19.2	22.8	25.2
	[in ³ /rev]	[0.51]	[0.66]	[0.88]	[1.03]	[1.17]	[1.39]	[1.54]
Peak pressure		270 [3916]	270 [3916]	270 [3916]	250 [3626]	230 [3336]	200 [2900]	180 [2610]
Rated pressure	bar [psi]	250 [3626]	250 [3626]	250 [3626]	230 [3336]	210 [3046]	180 [2610]	160 [2320]
Back pressure		250 [3626]	250 [3626]	250 [3626]	230 [3336]	210 [3046]	180 [2610]	160 [2320]
Maximum speed	min ⁻¹ (rpm)	3500	3500	3500	3500	3200	3200	3200
Minimum speed		700	700	700	500	500	500	500
Weight	kg [lb]	3.2 [7.05]	3.75 [8.26]	3.9 [8.60]	4.05 [8.93]	4.15 [9.15]	4.3 [9.48]	4.4 [9.70]
Moment of inertia of rotating components	x 10 ⁻⁶ kg·m ² [x 10 ⁻⁶ lb·ft ²]	32.4 [769]	38.4 [911]	47.3 [1122]	53.3 [1265]	59.2 [1405]	68.1 [1616]	74.1 [1758]



Product code

Model code

A	B	C	D	E	F	G	H	I	J	K	L	M	N	O
□ □ □ □ □ □ □ □	□ □ □ □	□	□	□ □	□ □	□ □	□ □	□ □	□ □	□	□	□ □ □ □	□	□

A Family

SGM2NC	Gr2 Fan Drive Bidirec.Motor-External Axial Drain
SGM2GC	Gr2 Fan Drive Unidirec Motor+Anticav.Check valve

B Displacement

8,0	8,4 cc
9,0	9,0 cc - Special
9,5	9,5 cc - Special
011	10,8 cc
012	12,0 cc - Special
014	14,4 cc
017	16,8 cc
019	19,2 cc
021	21,0 cc - Special
022	22,8 cc
025	25,2 cc

C Rotation

B	Bidirectional
L	Left rotation
R	Right rotation

D Project version

A	High Temperature sealing Dust protector Rust protected screws
----------	---------------------------------------------------------------------

E Mounting flange

01	European 01 flange, pilot Ø36,5+4 holes [Dia 1. in] 4-bolts Special for Fan Drive	
-----------	--------------------------------------------------------------------------------------------	--

02	European 02 flange, pilot Ø 80 mm [Dia 3.15 in] 4-bolts	
-----------	---------------------------------------------------------------	--

04	German flange pilot Ø50+2 holes through body Special for Fan Drive	
-----------	--------------------------------------------------------------------------	--

05	German flange pilot Ø50+2 holes through body Special for Fan Drive	
-----------	--------------------------------------------------------------------------	--

06	SAE A pilot Ø82,55+2 holes	
-----------	----------------------------	--

9Y	Outrigger Bearing with dust cover - SAE A flange pilot Ø 82,55 [Dia 3.25 in] 2-bolts - 1:8 Tapered shaft, Key 4 - M12 x 1.25	
-----------	------------------------------------------------------------------------------------------------------------------------------------------	--

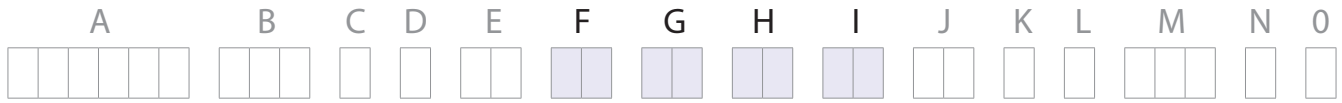

F Drive gear

AA	Taper 1:5-M12x1,25-Key 3	
-----------	--------------------------	--

FA	Parallel Ø15-L30-Key 4x25 Special for Fan Drive with Mounting flange 01	
-----------	-------------------------------------------------------------------------------	--

BA	Taper 1:8-M12x1,25-Key 4	
-----------	--------------------------	--

GB	Parallel SAE Ø15,875-L50,8- Key 4x40	
-----------	-----------------------------------------	--

G Rear cover

C5	Cast Iron cover with 7/8 - 14 UNF-2B In-Out Ports - 9/16- 18 UNF 2B Axial Drain (idler gear side)	
-----------	------------------------------------------------------------------------------------------------------------	--

CZ	Cast Iron cover with 7/8 - 14 UNF-2B In-Out Ports - 9/16- 18 UNF 2B Radial Drain (shaft side)	
-----------	--------------------------------------------------------------------------------------------------------	--

CX	Cast Iron cover with 7/8 14 UNF-2B In-Out Ports - 9/16- 18 UNF 2B Radial Drain (idler gear side)	
-----------	-----------------------------------------------------------------------------------------------------------	--

H Inlet port

NN	No inlet on body
-----------	------------------

I Outlet port

NN	No outlet on body
-----------	-------------------



J Ports Pos & Spec Body

NN	Std from catalogue
----	--------------------

K Seals

N	Standard high temperature seals
W	Standard high temperature seals without Dust Cover

L Screws

N	Rust protected screws
---	-----------------------

M Set valves

NNN	No Valve
-----	----------

N Type of mark

N	Standard marking
A	Standard + customer code
Z	Without marking
*	Special customer marking

O Mark position

N	Std Marking position (on top)
A	Special Marking position on the bottom



Mounting flange and shaft options

Turolla offers two types of industry standard mounting flanges :

“02” :European, pilot Ø 80 mm [Dia 3.15 in], 4-bolts

“06” : SAE A, pilot Ø 82.55 mm [Dia 3.25 in], 2-bolts.

The table below shows order codes for each available mounting flange and shaft:



Shaft/Flange		Maximum torque			
Code	Description	Code 01 flange	Code 02 flange	Code 06 flange	Code 9Y flange
01BA	European, pilot Ø 36.5 mm [1.44 in], 4-bolts Taper 1:8, Key 4 – M12 X 1,25	150 Nm [1328 lbin]			
01FA	European, pilot Ø 36.5 mm [1.44 in], 4-bolts Parallel Ø 15mm [0.591 in], L 36,5 [1.44 in]	90 Nm [797 lbin]			
02AA	European, pilot Ø 80 mm [Dia 3.15 in], 4-bolts Taper 1:5, Key 3 – M12 x 1.25		140 N•m [1239 lb•in]		
06BA	SAE A, pilot Ø 82.55 mm [Dia 3.25 in], 2-bolts Taper 1:8, Key 4 – M12 x 1.25	-		150 N•m [1328 lb•in]	
06GB	SAE A, pilot Ø 82.55 mm [Dia 3.25 in], 2-bolts Parallel Ø 15.875 [Dia 0.625], L 50.8 [2]	-		80 N•m [708 lb•in]	
9YDB	Outrigger Bearing with dust cover - SAE A flange pilot Ø 82,55 [Dia 3.25 in] 2-bolts 1:8 Tapered shaft, Key 4 – M12 x 1.25	-			130 Nm [1151 lbin]

Spline configuration is not available for Group 2 fan drive motors. Other shaft options may exist. Contact your Turolla representative for availability.

! Caution

Shaft torque capability may limit allowable pressure. Torque ratings assume no external radial loading. Applied torque must not exceed these limits, regardless of stated pressure parameters. Maximum torque ratings are based on shaft torsional fatigue strength.



SGM2NC • 02AA dimensions

mm
[in]

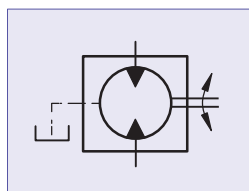
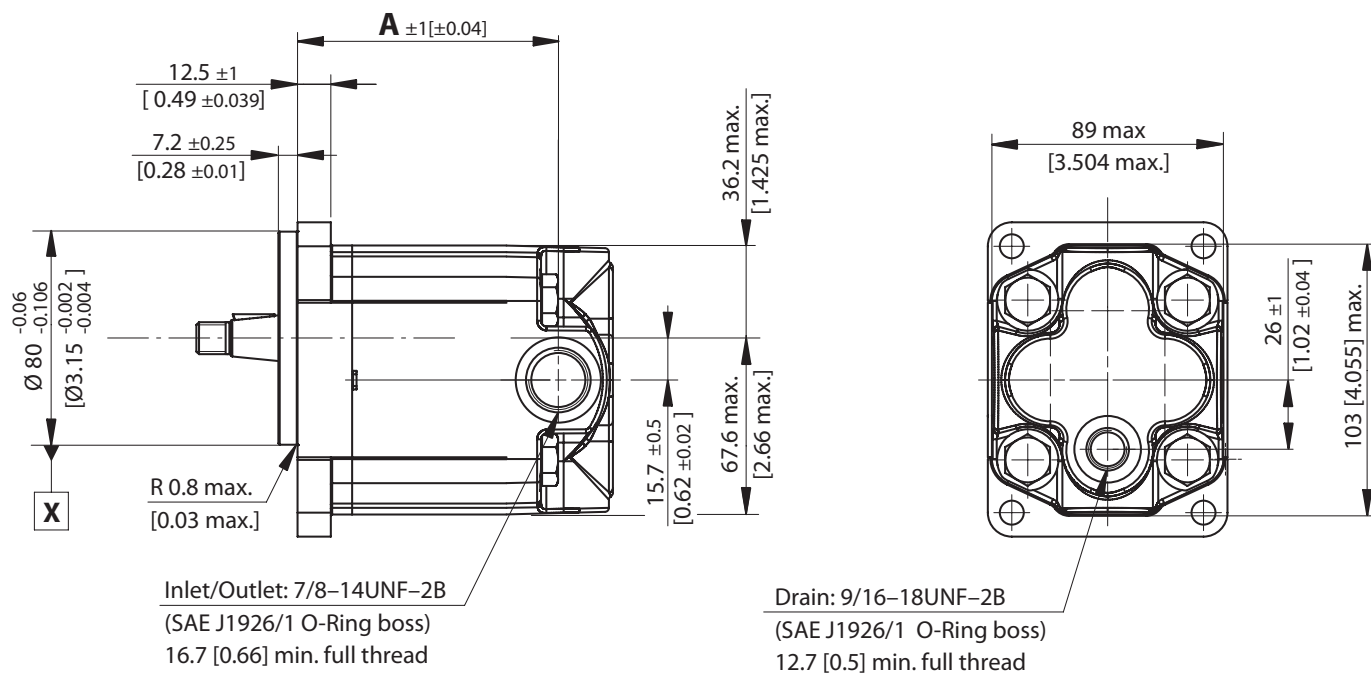
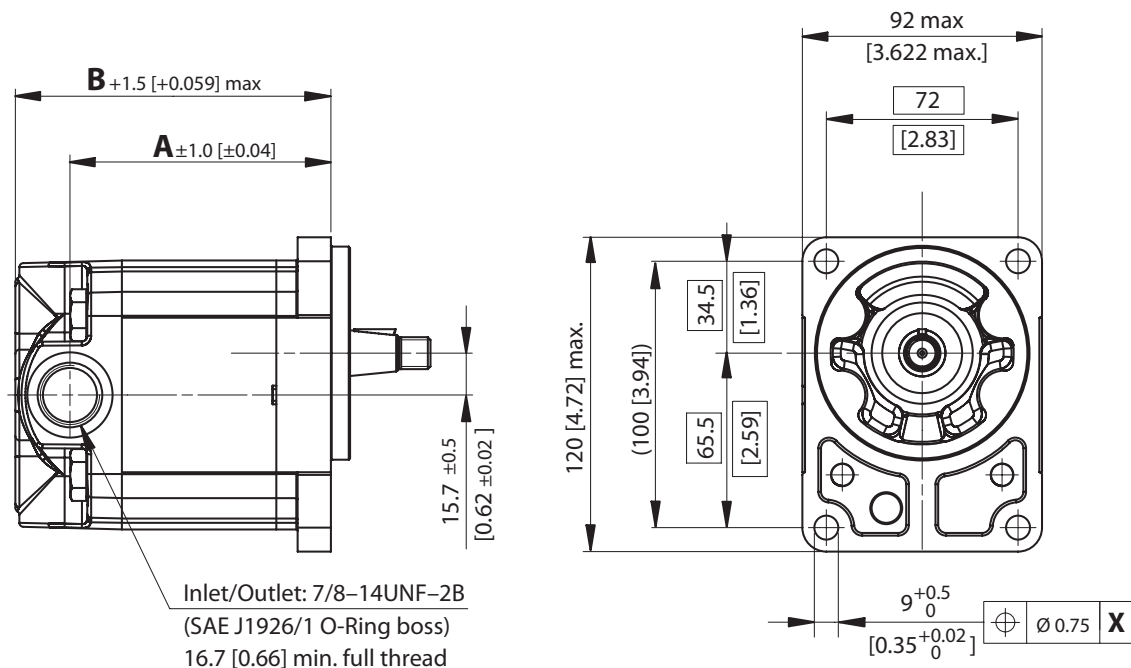

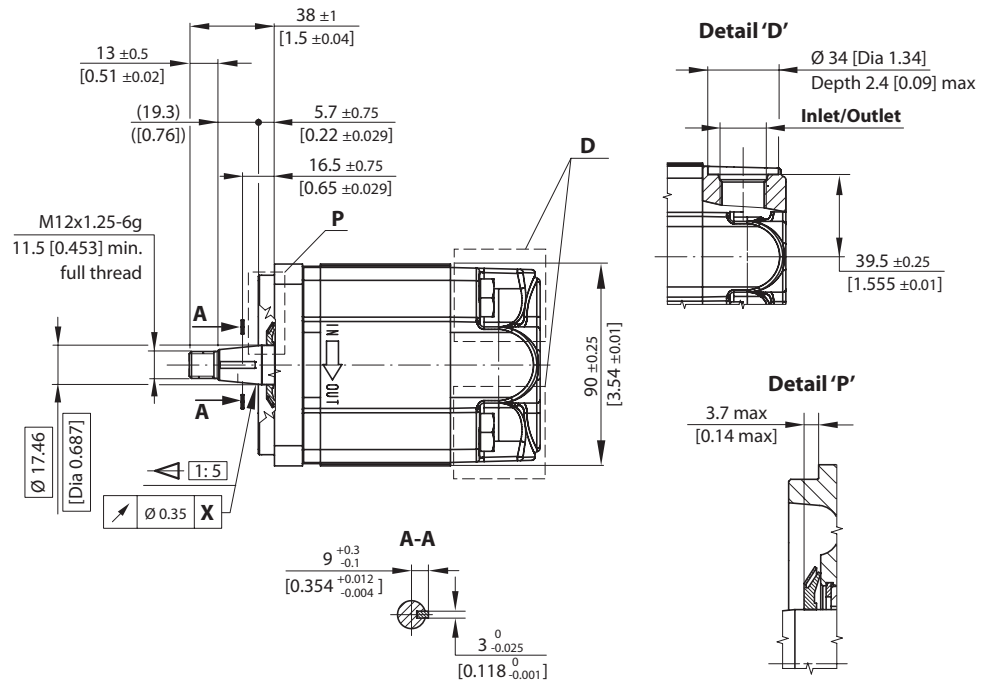

mm
[in]

SGM2NC – 02AA dimensions

Frame size	8,0	011	014	017	019	022	025
A	98 [3.86]	102 [4.01]	108 [4.25]	112 [4.41]	116 [4.57]	122 [4.80]	126 [4.96]
B	118.5 [4.66]	122.5 [4.83]	128.5 [5.05]	132.5 [5.22]	136.5 [5.37]	142.5 [5.61]	146.5 [5.77]
Inlet/Outlet	7/8–14UNF–2B (SAE J1926/1 O-Ring boss); 16.7 [0.66] min. full thread						
Drain port	9/16–18UNF–2B (SAE J1926/1 O-Ring boss); 12.7 [0.5] min. full thread						

Model code example and maximum shaft torque

Flange/shaft	Model code example	Maximum shaft torque
02AA	SGM2NC/011BA02AAC5NNNNNNNN/NNNNN	140 N·m [1239 lb·in]

For further details on ordering, see [Model Code](#), page 16 - 18.



SGM2NC • 06BA dimensions

mm
[in]

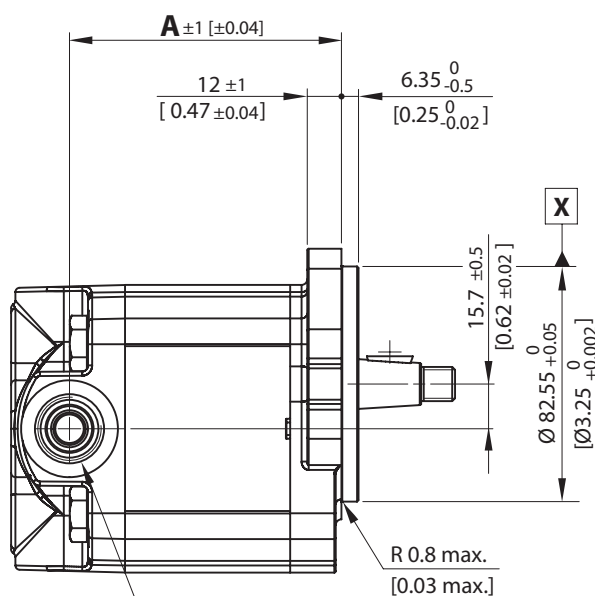

Inlet/Outlet: 7/8-14UNF-2B
(SAE J1926/1 O-Ring boss)
16.7 [0.66] min. full thread

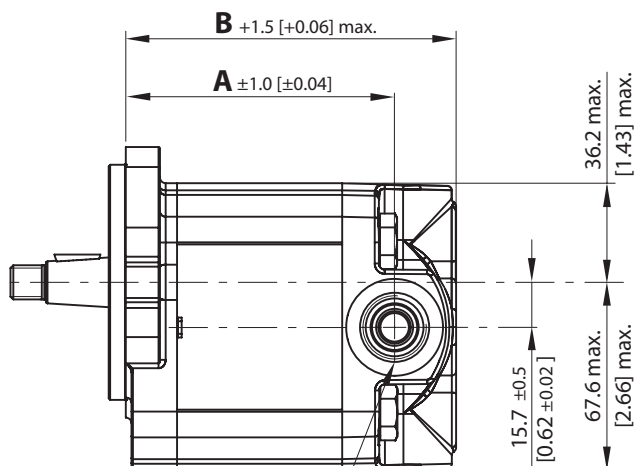
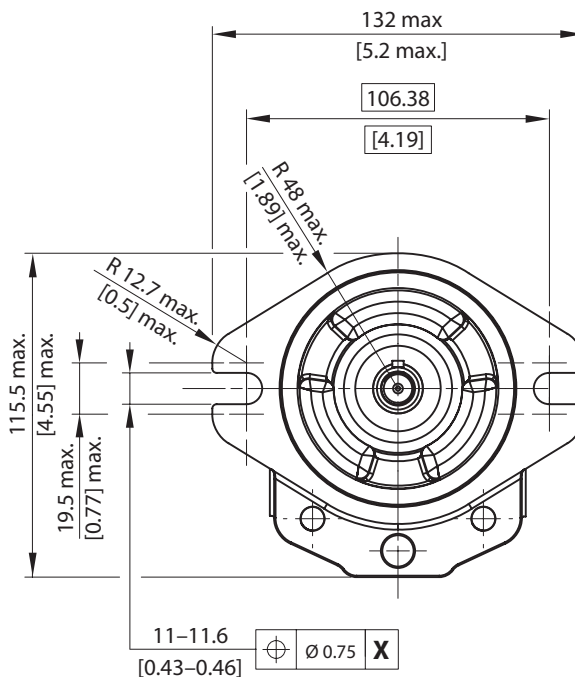

Inlet/Outlet: 7/8-14UNF-2B
(SAE J1926/1 O-Ring boss)
16.7 [0.66] min. full thread

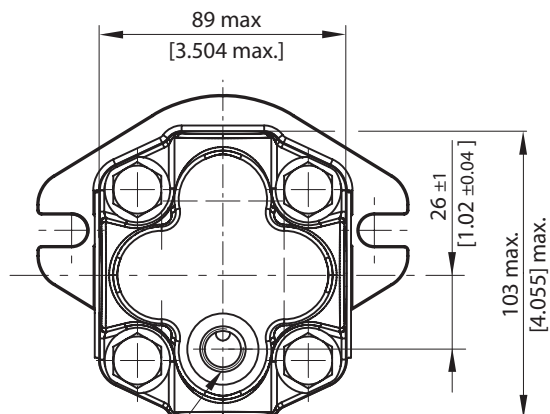

Drain: 9/16-18UNF-2B
(SAE J1926/1 O-Ring boss)
12.7 [0.5] min. full thread

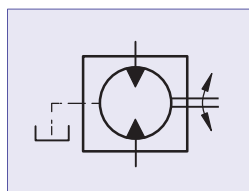

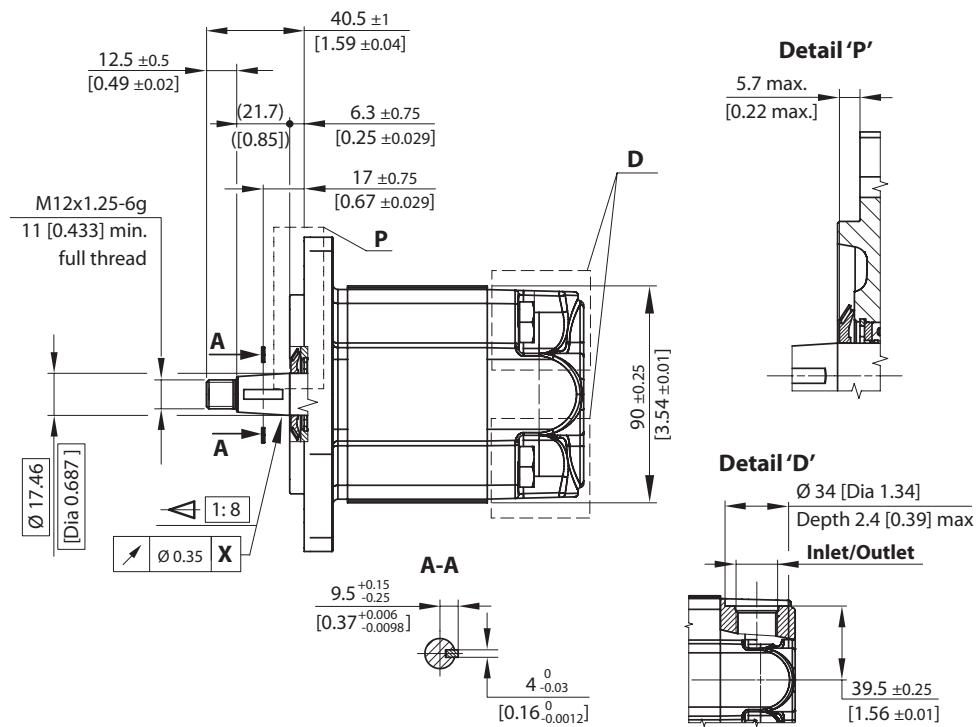

mm
[in]

SGM2NC – 06BA dimensions

Frame size	8,0	011	014	017	019	022	025
A	95.5 [3.76]	99.5 [3.92]	105.5 [4.15]	109.5 [4.31]	113.5 [4.47]	119.5 [4.70]	123.5 [4.86]
B	116 [4.57]	120 [4.72]	126 [4.96]	130 [5.11]	134 [5.28]	140 [5.51]	144 [5.67]
Inlet/Outlet	7/8–14UNF–2B (SAE J1926/1 O-Ring boss); 16.7 [0.66] min. full thread						
Drain port	9/16–18UNF–2B (SAE J1926/1 O-Ring boss); 12.7 [0.5] min. full thread						

Model code example and maximum shaft torque

Flange/shaft	Model code example	Maximum shaft torque
06BA	SGM2NC/011BA06BAC5NNNNNNNN/NNNNN	150 N·m [1328 lb·in]

For further details on ordering, see [Model Code](#), page 16 - 18.



SGM2NC • 06GB dimensions

mm
[in]

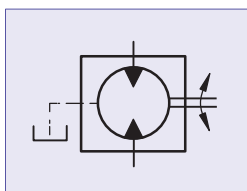
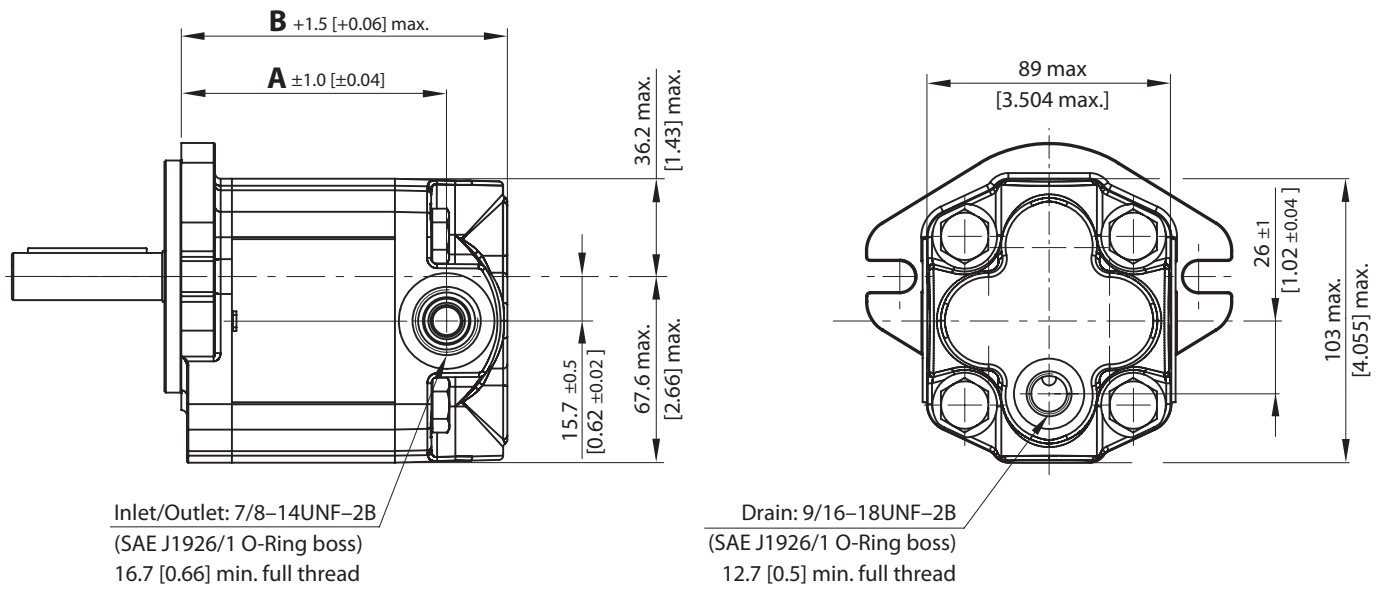
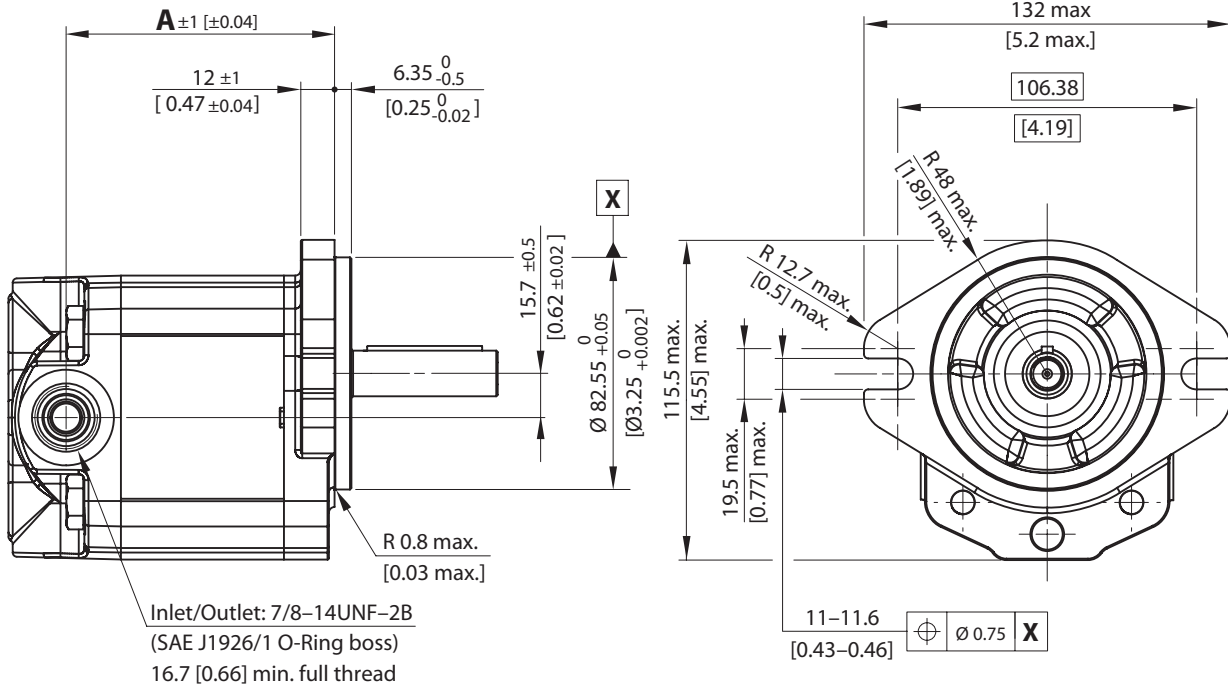

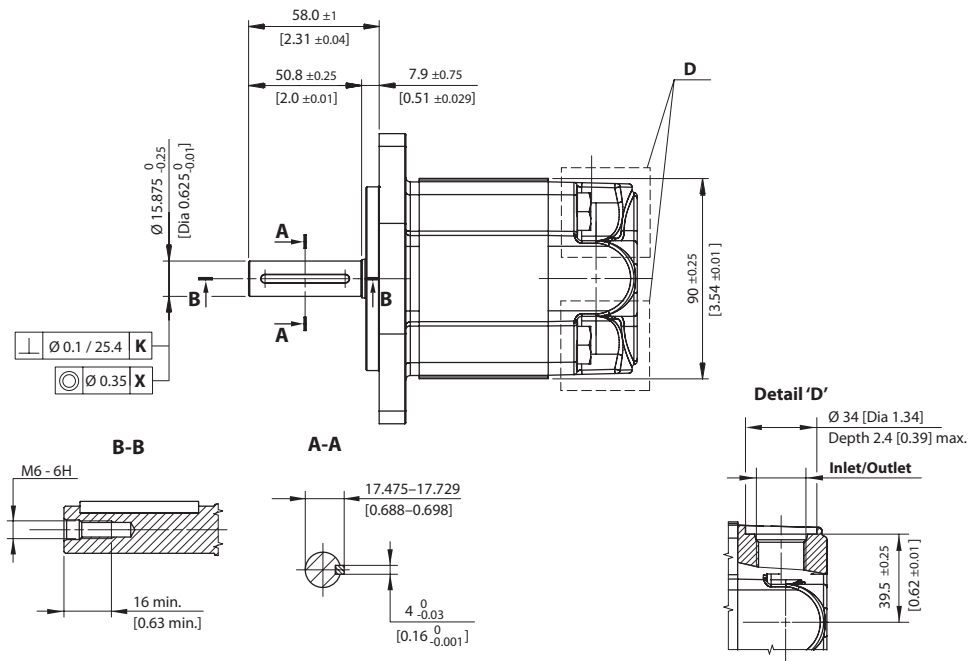

mm
[in]

SGM2NC – 06GB dimensions

Frame size	8,0	011	014	017	019	022	025
A	95.5 [3.76]	99.5 [3.92]	105.5 [4.15]	109.5 [4.31]	113.5 [4.47]	119.5 [4.70]	123.5 [4.86]
B	116 [4.57]	120 [4.72]	126 [4.96]	130 [5.11]	134 [5.28]	140 [5.51]	144 [5.67]
Inlet/Outlet	7/8–14UNF–2B (SAE J1926/1 O-Ring boss); 16.7 [0.66] min. full thread						
Drain port	9/16–18UNF–2B (SAE J1926/1 O-Ring boss); 12.7 [0.5] min. full thread						

Model code example and maximum shaft torque

Flange/shaft	Model code example	Maximum shaft torque
06GB	SGM2NC/011BA06GBC5NNNNNNNN/NNNNN	80 N·m [708 lb·in]

For further details on ordering, see [Model Code](#), page 16 - 18.



GROUP 2 FAN DRIVE GEAR MOTORS

SGM2YN

Motor design

SGM2YN is Group 2 fan drive motor with inlet on rear cover and outlet on body. Integrated proportional relief valve, anti-cavitation check valve and axial drain line.

Displacement range from 8.4 cm³/rev up to 25.2 cm³/rev [from 0.51 up to 1.54 in³/rev].

Configurations include European and SAE flanges; taper 1:8, taper 1:5 and parallel Ø15.875 mm [Dia 0,62 in] shafts.

Outrigger bearing available as SAE A flange with taper shaft 1:8 and European flange with taper shaft 1:5.

SGM2YN

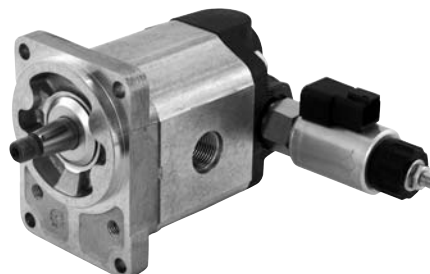

Technical data

Technical data for SGM2YN standard fan drive gear motors

Frame size		8,0	011	014	017	019	022	025
Displacement	cm ³ /rev	8.4	10.8	14.4	16.8	19.2	22.8	25.2
	[in ³ /rev]	[0.51]	[0.66]	[0.88]	[1.03]	[1.17]	[1.39]	[1.54]
Peak pressure	bar	270	270	270	250	230	200	180
		[3916]	[3916]	[3916]	[3626]	[3336]	[2900]	[2610]
Rated pressure	[psi]	250	250	250	230	210	180	160
		[3626]	[3626]	[3626]	[3336]	[3046]	[2610]	[2320]
Back pressure		150	150	150	150	130	100	100
		[2176]	[2176]	[2176]	[2176]	[1885]	[1450]	[1450]
Maximum speed	min ⁻¹ (rpm)	3500	3500	3500	3500	3200	3200	3200
Minimum speed		700	700	700	500	500	500	500
Weight	kg	4.73	4.83	5.03	5.18	5.23	5.33	5.53
		[10.43]	[10.65]	[11.1]	[11.42]	[11.53]	[11.75]	[12.2]
Moment of inertia of rotating components	x 10 ⁻⁶ kg·m ²	32.4	38.4	47.3	53.3	59.2	68.1	74.1
		[769]	[911]	[1122]	[1265]	[1405]	[1616]	[1758]



Electro proportional relief valve standard

Technical data

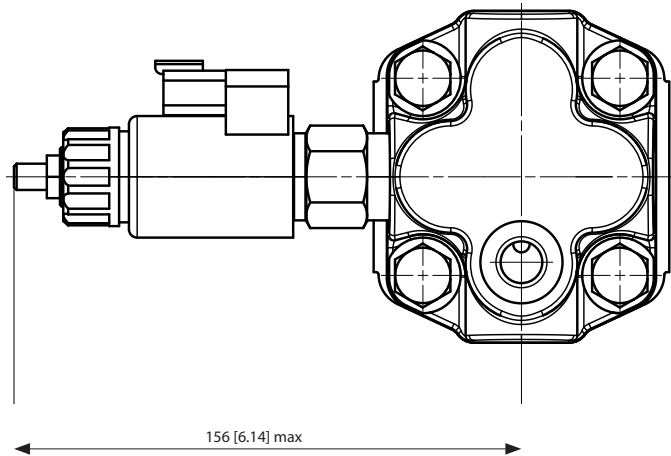

Electrical connectors	Deutsch DT 04-2P connectors (Protection rate IP 69K DIN 40050)
Electrical supply to EH valve	0 to 1.1 A @ 12 V DC, with coil resistance of 7.2 Ω @ 20 °C [68 °F] 0 to 0.55 A @ 24 V DC, with coil resistance of 28.8 Ω @ 20 °C [68 °F]
PWM frequency	from 100 to 200 Hz

Electro proportional relief valve flat curve

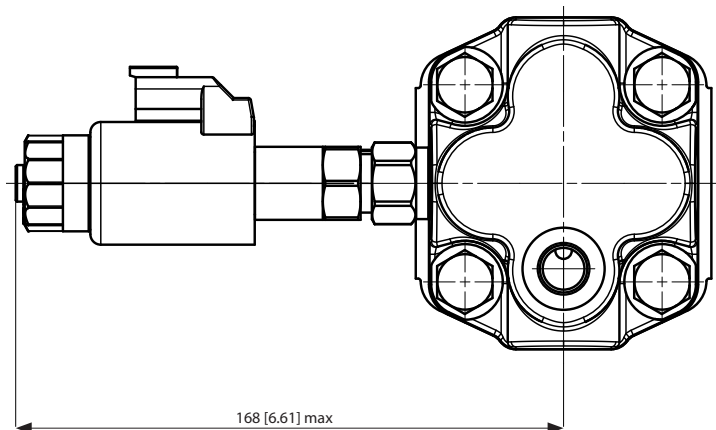

Electrical connectors	Deutsch DT 04-2P connectors (Protection rate IP 69K DIN 40050)
Electrical supply to EH valve	0 to 1.1 A @ 12 V DC, with coil resistance of 6.4 Ω @ 20 °C [68 °F] 0 to 0.55 A @ 24 V DC, with coil resistance of 26.2 Ω @ 20 °C [68 °F]
PWM frequency	from 100 to 250 Hz



Product code

Model code



A Family

SGM2YN	Gr2 Fan Drive Motor with Proportional Pressure Valve, Axial Drain
SGM2YL	Gr2 Fan Drive Motor with Proportional Pressure Valve, Radial Drain

B Displacement

8,0	8,4 cc
9,0	9,0 cc - Special
9,5	9,5 cc - Special
011	10,8 cc
012	12,0 cc - Special
014	14,4 cc
017	16,8 cc
019	19,2 cc
021	21,0 cc - Special
022	22,8 cc
025	25,2 cc

C Rotation

L	Left rotation
R	Right rotation

D Project version

A	High Temperature sealing Dust protector Rust protected screws
----------	---------------------------------------------------------------------

E Mounting flange

01	European 01 flange, pilot Ø36,5+4 holes [Dia 1. in] 4-bolts Special for Fan Drive	
-----------	--------------------------------------------------------------------------------------------	--

02	European 02 flange, pilot Ø 80 mm [Dia 3.15 in] 4-bolts	
-----------	---------------------------------------------------------------	--

04	German flange pilot Ø50 +2 holes through body Special for Fan Drive	
-----------	---------------------------------------------------------------------------	--

05	German flange pilot Ø50 +2 holes through body Special for Fan Drive	
-----------	---------------------------------------------------------------------------	--

06	SAE A pilot Ø82,55 +2 holes	
-----------	--------------------------------	--

9Y	Outrigger Bearing with dust cover - SAE A flange pilot Ø 82,55 [Dia 3.25 in] 2-bolts - 1:8 Tapered shaft, Key 4 - M12 x 1.25	
-----------	---------------------------------------------------------------------------------------------------------------------------------------	--

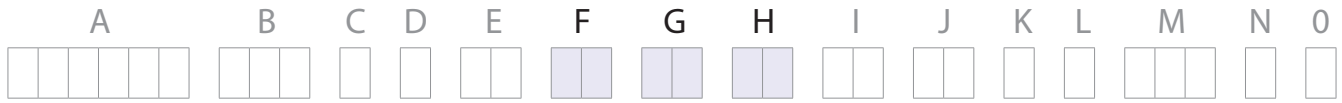

F Drive gear

AA	Taper 1:5-M12x1,25-Key 3	
-----------	--------------------------	--

FA	Parallel Ø15-L30-Key 4x25 Special for Fan Drive with Mounting flange 01	
-----------	-------------------------------------------------------------------------------	--

BA	Taper 1:8-M12x1,25-Key 4	
-----------	--------------------------	--

GB	Parallel SAE Ø15,875-L50,8- Key 4x40	
-----------	-----------------------------------------	--

G Rear cover

Y6	Cast Iron cover with 7/8 - 14 UNF-2B In Port - 9/16-18 UNF 2B Axial Drain (idler gear side)	
-----------	------------------------------------------------------------------------------------------------------	--

YX	Cast Iron cover with 7/8 - 14 UNF-2B In Port - 9/16-18 UNF 2B Radial Drain (shaft side)	
-----------	--------------------------------------------------------------------------------------------------	--

Y4	Cast Iron cover with 7/8 14 UNF-2B In Port - 9/16-18 UNF 2B Radial Drain (idler gear side)	
-----------	-----------------------------------------------------------------------------------------------------	--

H Inlet port

NN	No inlet on body
-----------	------------------



I Outlet port

B5	15x35xM6	
B6	15x40xM6	
B7	20x40xM6	
D7	M22x1,5	
D9	M26x1,5	
E5	7/8-14UNF	
E6	1-1/16-12UN	

F4	1/2 GAS	
F5	3/4 GAS	
H5	M18x1,5-ISO6149	
H7	M22x1,5-ISO6149	
H8	M27x2-ISO6149	

J Ports Pos & Spec Body

NN	Std from catalogue
YY	Port Bx-Bx with flange SAE-A; off-set to rear cover
ZZ	Port Bx-Bx in the center of the body - Option

K Seals

N	Standard high temperature seals
W	Standard high temperature seals without Dust Cover

L Screws

N	Rust protected screws
----------	-----------------------



A B C D E F G H I J K L M N O

M Set valves

XNN	No valve										
XA*	Standard relief valve with coil voltage 12 V DC, DT connector										
XB*	Standard relief valve with coil voltage 24 V DC, DT connector										
<table border="1"> <tr><td>X*F</td><td rowspan="8">Select Pressure vs. Bypass flow requirements using the graph below. Three color curves represent three types of valves. Each valve is characterized by different nominal spring ranges.</td></tr> <tr><td>X*I</td></tr> <tr><td>X*M</td></tr> <tr><td>X*O</td></tr> <tr><td>X*Q</td></tr> <tr><td>X*S</td></tr> <tr><td>X*U</td></tr> <tr><td>X*W</td></tr> <tr><td>X*Y</td></tr> </table>	X*F	Select Pressure vs. Bypass flow requirements using the graph below. Three color curves represent three types of valves. Each valve is characterized by different nominal spring ranges.	X*I	X*M	X*O	X*Q	X*S	X*U	X*W	X*Y	<p>The graph plots Δ Pressure against Bypass flow. The y-axis has two scales: psi (0 to 4000) and bar (0 to 300). The x-axis has two scales: l/min (0 to 80) and US gal/min (0 to 20). Multiple curves are shown, labeled F, I, M, O, Q, S, U, W, and Y. Curves F, I, and M are solid black lines. Curves O, Q, S, U, W, and Y are solid green lines. The curves generally show an upward trend of pressure with increasing flow.</p>
X*F	Select Pressure vs. Bypass flow requirements using the graph below. Three color curves represent three types of valves. Each valve is characterized by different nominal spring ranges.										
X*I											
X*M											
X*O											
X*Q											
X*S											
X*U											
X*W											
X*Y											
SA*	Flat curve valve with coil voltage 12 V DC, DT connector										
SB*	Flat curve valve with coil voltage 24 V DC, DT connector										
<table border="1"> <tr><td>S*O</td><td rowspan="5"> <p>The graph plots Pressure against Bypass flow. The y-axis has two scales: bar (0 to 4500) and psi (0 to 300). The x-axis is Bypass flow in US gal/min (0 to 20). Four curves are shown, labeled O, S, W, and X. Curves O, S, W, and X are solid black lines. The curves are relatively flat, showing a slight upward trend of pressure with increasing flow.</p> </td></tr> <tr><td>S*S</td></tr> <tr><td>S*W</td></tr> <tr><td>S*X</td></tr> <tr><td>S*W</td></tr> <tr><td>S*X</td></tr> </table>	S*O	<p>The graph plots Pressure against Bypass flow. The y-axis has two scales: bar (0 to 4500) and psi (0 to 300). The x-axis is Bypass flow in US gal/min (0 to 20). Four curves are shown, labeled O, S, W, and X. Curves O, S, W, and X are solid black lines. The curves are relatively flat, showing a slight upward trend of pressure with increasing flow.</p>	S*S	S*W	S*X	S*W	S*X				
S*O	<p>The graph plots Pressure against Bypass flow. The y-axis has two scales: bar (0 to 4500) and psi (0 to 300). The x-axis is Bypass flow in US gal/min (0 to 20). Four curves are shown, labeled O, S, W, and X. Curves O, S, W, and X are solid black lines. The curves are relatively flat, showing a slight upward trend of pressure with increasing flow.</p>										
S*S											
S*W											
S*X											
S*W											
S*X											



Model code continued



N Type of mark

N	Standard marking
A	Standard + customer code
Z	Without marking
*	Special customer marking

O Mark position

N	Std Marking position (on top)
A	Special Marking position on the bottom



Mounting flange and shaft options

Turolla offers two types of industry standard mounting flanges :

“02” :European, pilot Ø 80 mm [Dia 3.15 in], 4-bolts

“06” : SAE A, pilot Ø 82.55 mm [Dia 3.25 in], 2-bolts.

The table below shows order codes for each available mounting flange and shaft:



Shaft/Flange		Maximum torque			
Code	Description	Code 01 flange	Code 02 flange	Code 06 flange	Code 9Y flange
01BA	European, pilot Ø 36.5 mm [1.44 in], 4-bolts Taper 1:8, Key 4 – M12 X 1,25	150 Nm [1328 lbin]			
01FA	European, pilot Ø 36.5 mm [1.44 in], 4-bolts Parallel Ø 15mm [0.591 in], L 36,5 [1.44 in]	90 Nm [797 lbin]			
02AA	European, pilot Ø 80 mm [Dia 3.15 in], 4-bolts Taper 1:5, Key 3 – M12 x 1.25		140 N•m [1239 lb•in]		
06BA	SAE A, pilot Ø 82.55 mm [Dia 3.25 in], 2-bolts Taper 1:8, Key 4 – M12 x 1.25	-		150 N•m [1328 lb•in]	
06GB	SAE A, pilot Ø 82.55 mm [Dia 3.25 in], 2-bolts Parallel Ø 15.875 [Dia 0.625], L 50.8 [2]	-		80 N•m [708 lb•in]	
9YDB	Outrigger Bearing with dust cover - SAE A flange pilot Ø 82,55 [Dia 3.25 in] 2-bolts 1:8 Tapered shaft, Key 4 – M12 x 1.25	-			130 Nm [1151 lbin]

Spline configuration is not available for Group 2 fan drive motors. Other shaft options may exist. Contact your Turolla representative for availability.

! Caution

Shaft torque capability may limit allowable pressure. Torque ratings assume no external radial loading. Applied torque must not exceed these limits, regardless of stated pressure parameters. Maximum torque ratings are based on shaft torsional fatigue strength.



SGM2YN • 02AA dimensions

mm
[in]

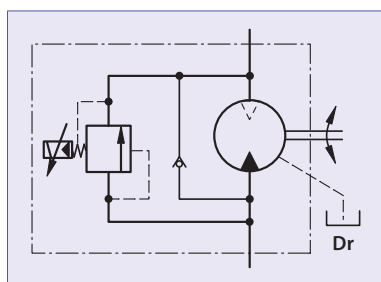
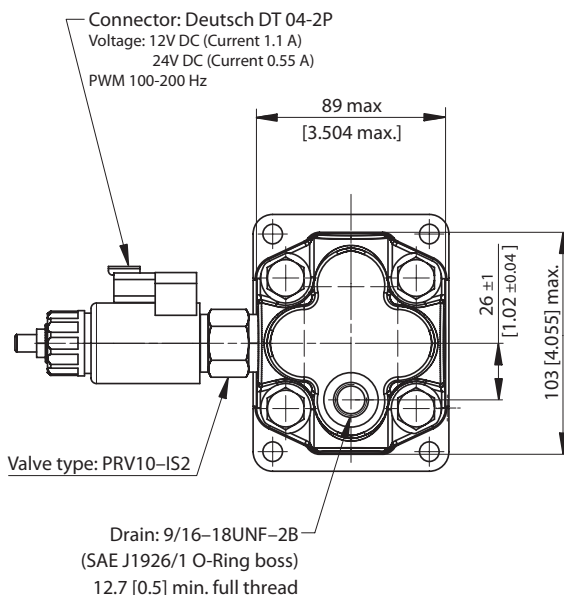
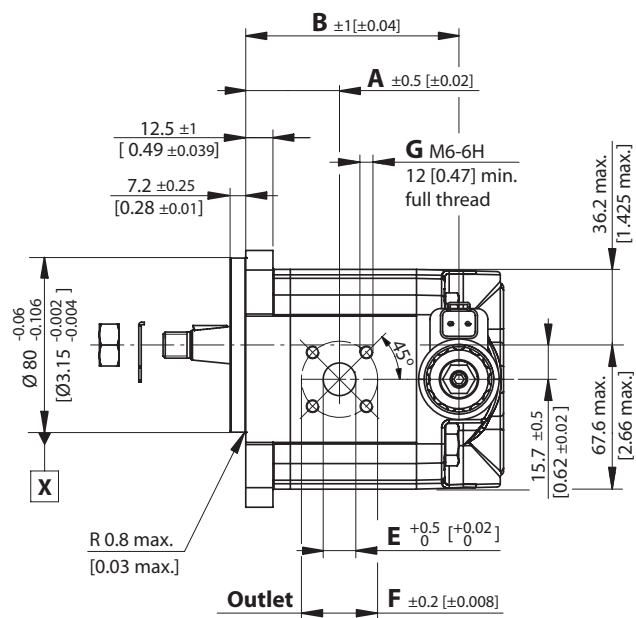
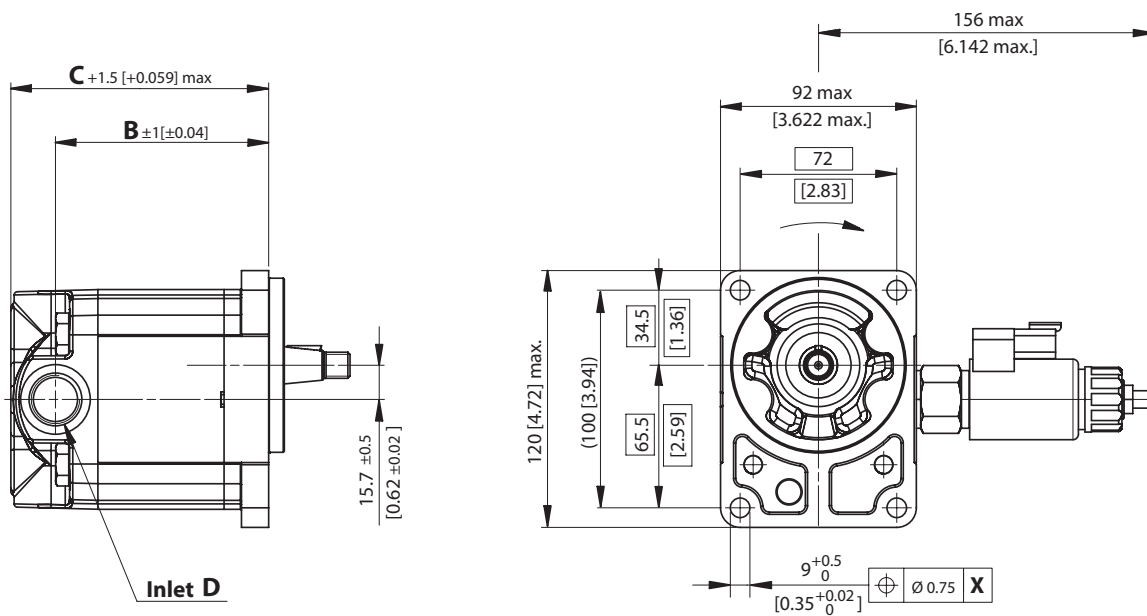

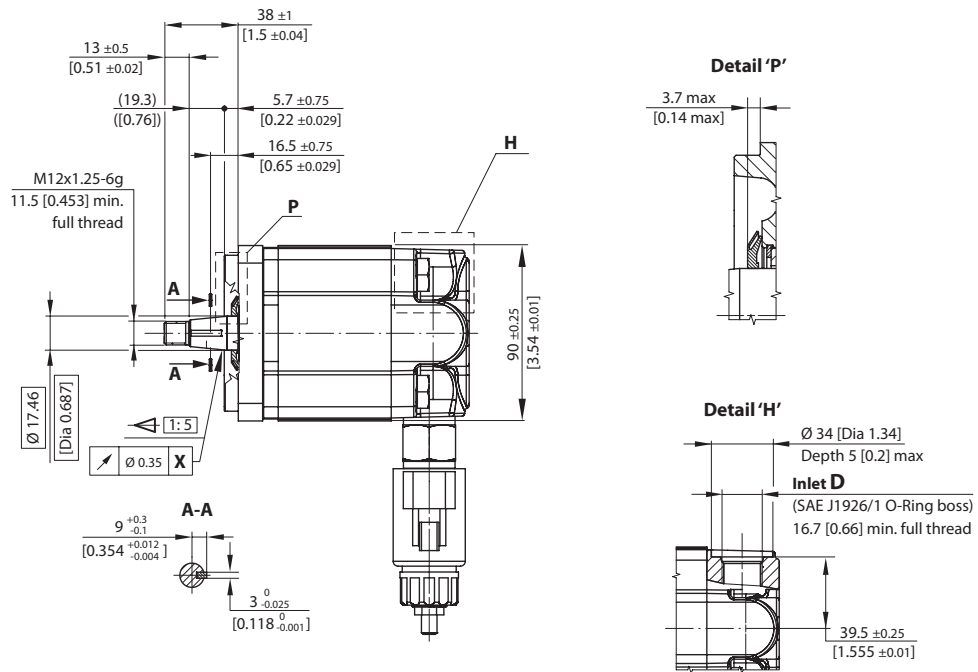

mm
[in]

SGM2YN – 02AA dimensions

Frame size		8,0	011	014	017	019	022	025
Dimension	A	43.1 [1.70]	47.5 [1.87]	47.5 [1.87]	47.5 [1.87]	47.5 [1.87]	55.0 [2.17]	64.5 [2.54]
	B	98 [3.86]	102 [4.01]	108 [4.25]	112 [4.41]	116 [4.57]	122 [4.80]	126 [4.96]
	C	118.5 [4.66]	122.5 [4.83]	128.5 [5.05]	132.5 [5.22]	136.5 [5.37]	142.5 [5.61]	146.5 [5.77]
Inlet	D	7/8-14UNF-2B (SAE J1926/1 O-Ring boss); 16.7 [0.66] min. full thread						
Outlet	E	15 [0.59]	20 [0.79]					
	F	35 [0.38]	40 [0.57]					
	G	M6-6H; 12 [0.47] min. full thread						
Drain port		9/16-18UNF-2B (SAE J1926/1 O-Ring boss); 12.7 [0.5] min. full thread						

Inlet is always the same.

Model code example and maximum shaft torque

Flange/shaft	Model code example	Maximum shaft torque
02AA	SGM2YN/014LA02AAY6NNE5NNNN/XNNNN	140 N·m [1239 lb·in]

For further details on ordering, see [Model Code](#), pages 28 - 32.



SGM2YN • 06BA dimensions

mm
[in]

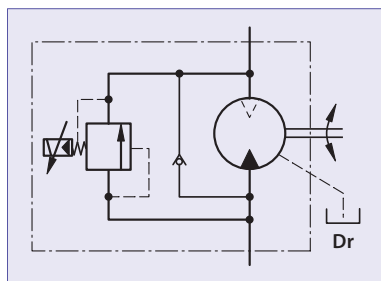
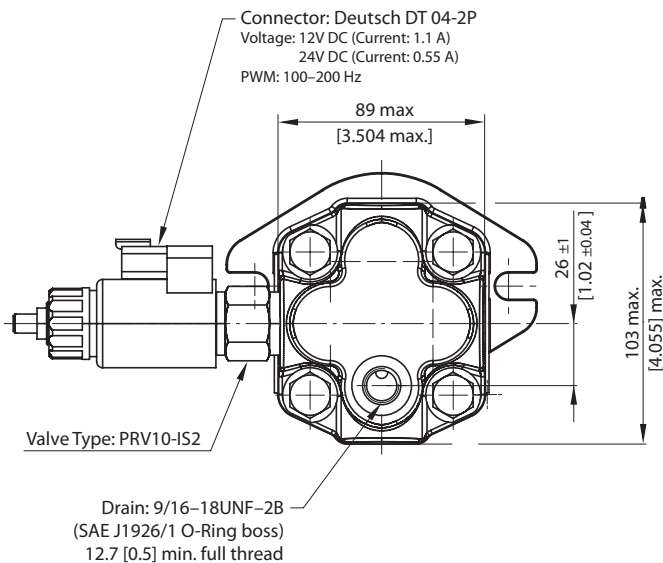
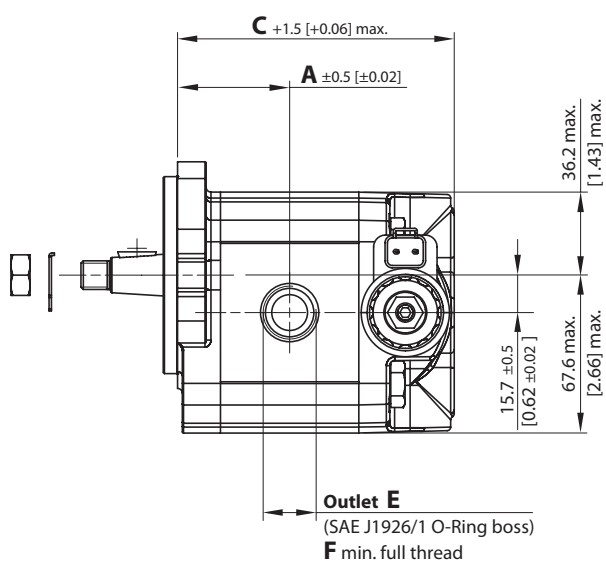
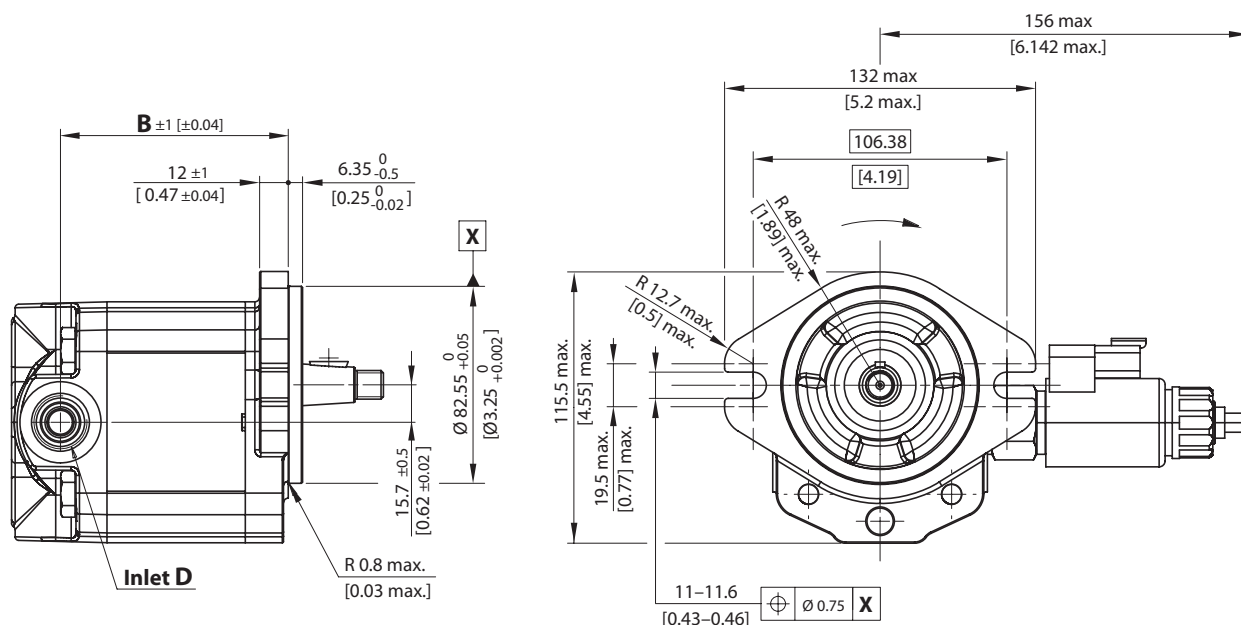

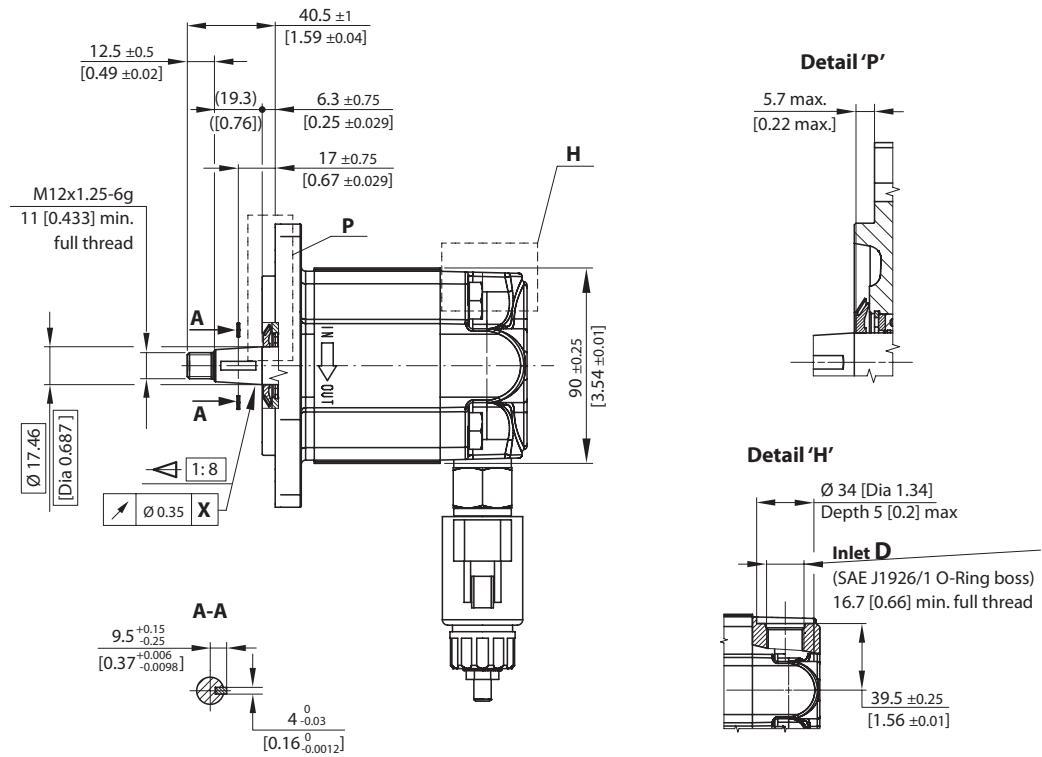

mm
[in]

SGM2YN – 06BA dimensions

Frame size		8,0	011	014	017	019	022	025
Dimension	A	47 [1.85]	49 [1.93]	52 [2.05]	54 [2.13]	56 [2.21]	59 [2.32]	61 [2.40]
	B	95.5 [3.76]	99.5 [3.92]	105.5 [4.15]	109.5 [4.31]	113.5 [4.47]	119.5 [4.70]	123.5 [4.86]
	C	116 [4.57]	120 [4.72]	126 [4.96]	130 [5.11]	134 [5.28]	140 [5.51]	144 [5.67]
Inlet	D	7/8–14UNF–2B (SAE J1926/1 O-Ring boss); 16.7 [0.66] min. full thread						
Outlet	E	7/8–14UNF–2B			1–1/16–12UN–2B			
	F	16.7 [0.66] min. full thread			19 [0.75] min. full thread			
Drain port		9/16–18UNF–2B (SAE J1926/1 O-Ring boss); 12.7 [0.5] min. full thread						

Inlet is always the same.

Model code example and maximum shaft torque

Flange/shaft	Model code example	Maximum shaft torque
06BA	SGM2YN/025RA06BAY6NNE6N>NNN/X>NNNN	150 N·m [1328 lb·in]

For further details on ordering, see [Model Code](#), pages 28 - 32.



SGM2YN • 06GB dimensions

mm
[in]

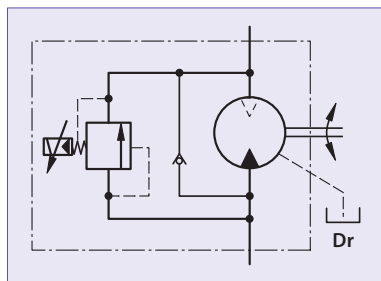
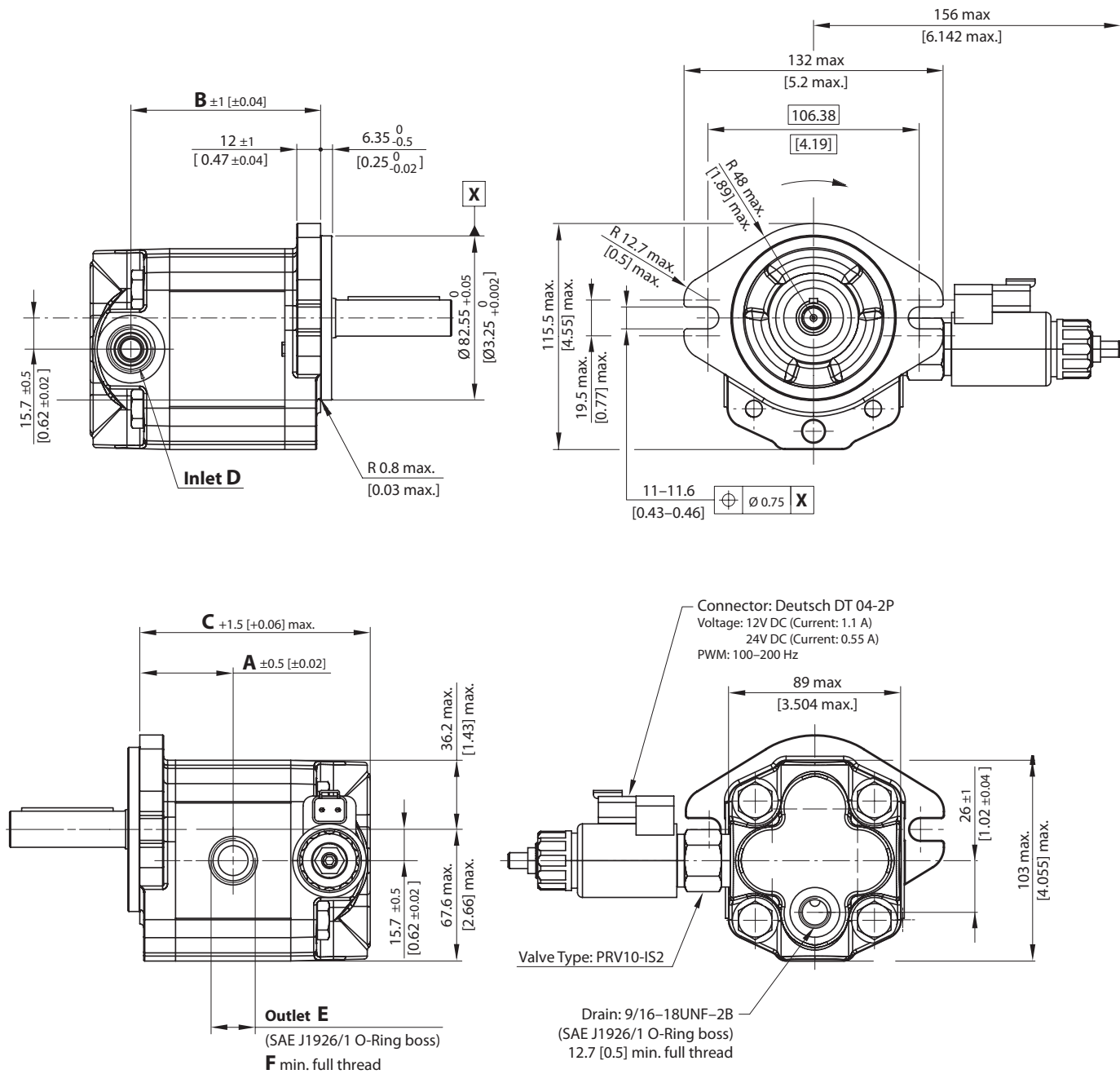

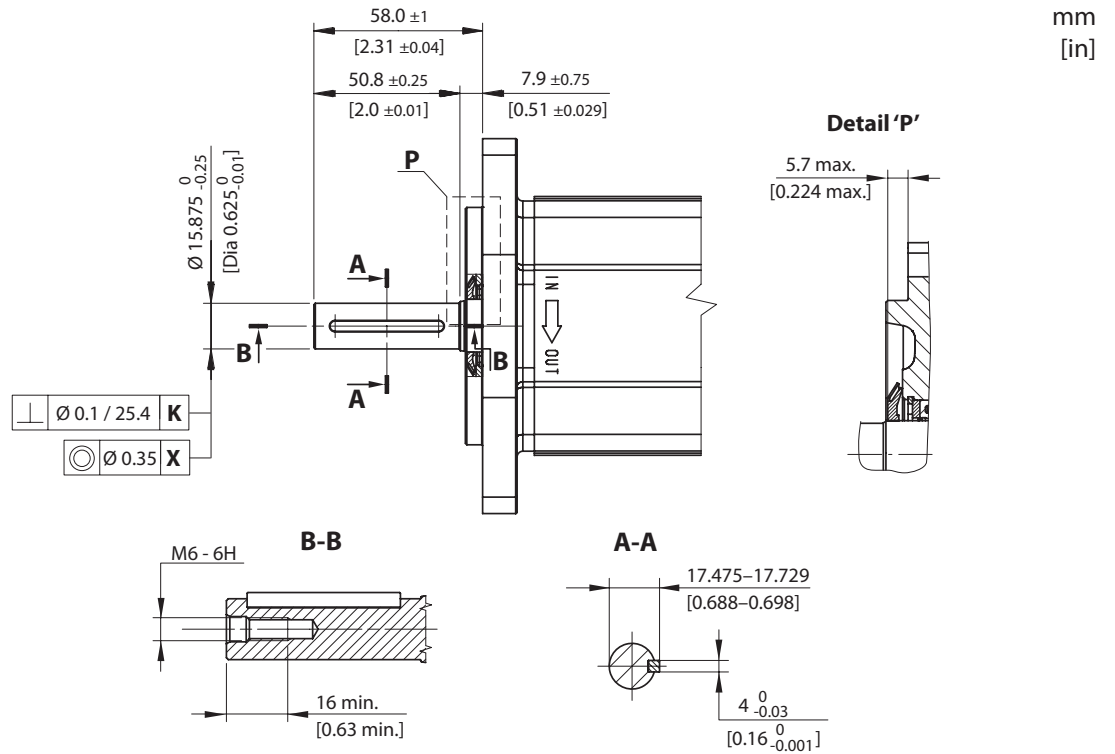

SGM2YN – 06GB dimensions

Frame size		8,0	011	014	017	019	022	025
Dimension	A	47 [1.85]	49 [1.93]	52 [2.05]	54 [2.13]	56 [2.21]	59 [2.32]	61 [2.40]
	B	95.5 [3.76]	99.5 [3.92]	105.5 [4.15]	109.5 [4.31]	113.5 [4.47]	119.5 [4.70]	123.5 [4.86]
	C	116 [4.57]	120 [4.72]	126 [4.96]	130 [5.11]	134 [5.28]	140 [5.51]	144 [5.67]
Inlet	D	7/8–14UNF–2B (SAE J1926/1 O-Ring boss); 16.7 [0.66] min. full thread						
Outlet	E	7/8–14UNF–2B				1–1/16–12UN–2B		
	F	16.7 [0.66] min. full thread				19 [0.75] min. full thread		
Drain port		9/16–18UNF–2B (SAE J1926/1 O-Ring boss); 12.7 [0.5] min. full thread						

Inlet is always the same.

Model code example and maximum shaft torque

Flange/shaft	Model code example	Maximum shaft torque
06GB	SGM2YN/022L406GBY6NNE6N>NNN/XNNNN	80 N•m [708 lb•in]

For further details on ordering, see [Model Code](#), pages 28 - 32.



GROUP 2 FAN DRIVE GEAR MOTORS SGM2VC

Motor design

SGM2VC is Group 2 fan drive motor with integrated DCV valve for "reverse function", anti-shock and proportional relief valve. Inlet/outlet and radial drain line are on cast iron rear cover.

Displacement range from 8.4 cm³/rev up to 25.2 cm³/rev [from 0.51 up to 1.54 in³/rev].

Configurations include European and SAE flanges; taper 1:8, taper 1:5 and parallel Ø15.875 mm [Dia 0,62 in] shafts.

Outrigger bearing available as SAE A flange with taper shaft 1:8 and European flange with taper shaft 1:5.

SGM2VC



Technical data

Technical data for SGM2VC standard fan drive gear motors

Frame size		8,0	011	014	017	019	022	025
Displacement	cm ³ /rev	8.4	10.8	14.4	16.8	19.2	22.8	25.2
	[in ³ /rev]	[0.51]	[0.66]	[0.88]	[1.03]	[1.17]	[1.39]	[1.54]
Peak pressure	bar	270	270	270	250	230	200	180
		[3916]	[3916]	[3916]	[3626]	[3336]	[2900]	[2610]
Rated pressure	[psi]	250	250	250	230	210	180	160
		[3626]	[3626]	[3626]	[3336]	[3046]	[2610]	[2320]
Back pressure	bar	150	150	150	150	130	100	100
		[2176]	[2176]	[2176]	[2176]	[1885]	[1450]	[1450]
Maximum speed	min ⁻¹ (rpm)	3500	3500	3500	3500	3200	3200	3200
		700	700	700	500	500	500	500
Minimum speed	min ⁻¹ (rpm)	700	700	700	500	500	500	500
		3500	3500	3500	3500	3200	3200	3200
Weight	kg	8.41	8.96	9.11	9.26	9.36	9.51	9.61
		[18.54]	[19.75]	[20.08]	[20.41]	[20.63]	[20.96]	[21.19]
Moment of inertia of rotating components	x 10 ⁻⁶ kg·m ²	32.4	38.4	47.3	53.3	59.2	68.1	74.1
		[769]	[911]	[1122]	[1265]	[1405]	[1616]	[1758]



Electro proportional relief valve - standard and D03 directional valve

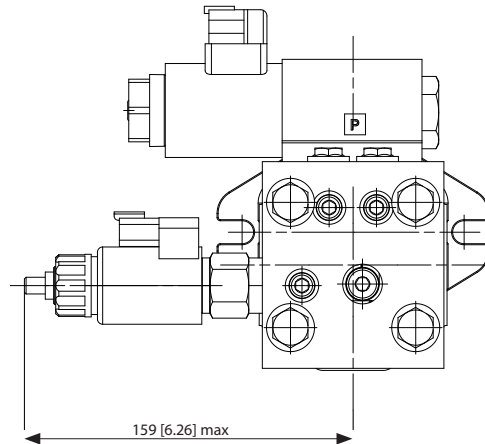

Electrical connectors	Deutsch DT 04-2P connectors (Protection rate IP 69K DIN 40050)
Electrical supply to EH valve	0 to 1.1 A @ 12 V DC, with coil resistance of 7.2 Ω @ 20 °C [68 °F] 0 to 0.55 A @ 24 V DC, with coil resistance of 28.8 Ω @ 20 °C [68 °F]
Directional valve coil	12 - 24 V DC
PWM frequency	from 100 to 200 Hz

Electro proportional relief valve - flat curve and D03 directional valve

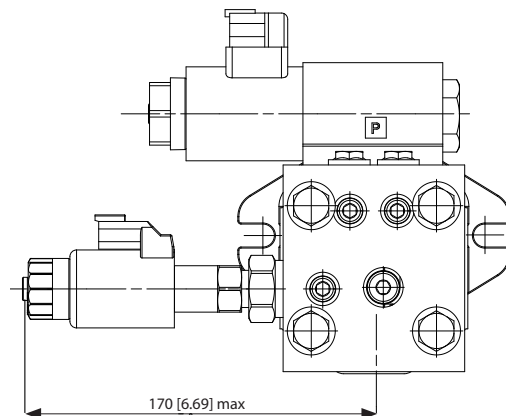

Electrical connectors	Deutsch DT 04-2P connectors (Protection rate IP 69K DIN 40050)
Electrical supply to EH valve	0 to 1.1 A @ 12 V DC, with coil resistance of 6.4 Ω @ 20 °C [68 °F] 0 to 0.55 A @ 24 V DC, with coil resistance of 26.2 Ω @ 20 °C [68 °F]
Directional valve coil	12 - 24 V DC
PWM frequency	from 100 to 250 Hz



Product code

Model code



A Family

SGM2VC Gr2 Reversible Fan Drive Motor with Proportional Pressure Valve

B Displacement

8,0	8,4 cc
9,0	9,0 cc - Special
9,5	9,5 cc - Special
011	10,8 cc
012	12,0 cc - Special
014	14,4 cc
017	16,8 cc
019	19,2 cc
021	21,0 cc - Special
022	22,8 cc
025	25,2 cc

C Rotation

L	Left rotation
R	Right rotation

D Project version

A	High Temperature sealing Dust protector Rust protected screws
---	---------------------------------------------------------------------

E Mounting flange

01	European 01 flange, pilot Ø36,5+4 holes [Dia 1. in] 4-bolts Special for Fan Drive	
-----------	--------------------------------------------------------------------------------------------	--

05	German flange pilot Ø50 +2 holes through body Special for Fan Drive	
-----------	---------------------------------------------------------------------------	--

02	European 02 flange, pilot Ø 80 mm [Dia 3.15 in] 4-bolts	
-----------	---------------------------------------------------------------	--

06	SAE A pilot Ø82,55 +2 holes	
-----------	--------------------------------	--

04	German flange pilot Ø50 +2 holes through body Special for Fan Drive	
-----------	---------------------------------------------------------------------------	--

9Y	Outrigger Bearing with dust cover - SAE A flange pilot Ø 82,55 [Dia 3.25 in] 2-bolts - 1:8 Tapered shaft, Key 4 - M12 x 1.25	
-----------	---------------------------------------------------------------------------------------------------------------------------------------	------



A	B	C	D	E	F	G	H	I	J	K	L	M	N	O
<input type="checkbox"/>	<input type="checkbox"/>	<input type="checkbox"/>	<input type="checkbox"/>	<input type="checkbox"/>	<input checked="" type="checkbox"/>	<input checked="" type="checkbox"/>	<input checked="" type="checkbox"/>	<input checked="" type="checkbox"/>	<input checked="" type="checkbox"/>	<input type="checkbox"/>	<input type="checkbox"/>	<input type="checkbox"/>	<input type="checkbox"/>	<input type="checkbox"/>

F Drive gear

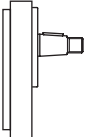
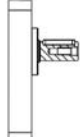
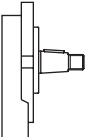
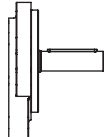
AA	Taper 1:5-M12x1,25-Key 3		FA	Parallel Ø15-L30-Key 4x25 Special for Fan Drive with Mounting flange 01	
BA	Taper 1:8-M12x1,25-Key 4		GB	Parallel SAE Ø15,875-L50, 8-Key 4x40	

G Rear cover

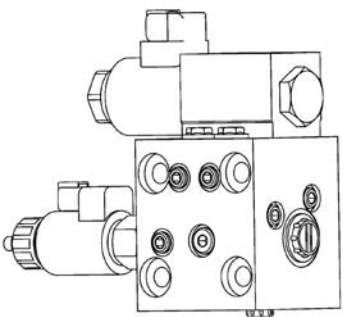
RA	Proportional PRV Reversing Valve Cover, 12 V DCV03 Deutsch connector, Anti-Shock-MakeUp Valve, 7/8-14 UNF Work Ports, 9/16-18 UNF Radial Drain Port	
RB	Proportional PRV Reversing Valve Cover, 24 V DCV03 Deutsch connector, Anti-Shock-MakeUp Valve, 7/8-14 UNF Work Ports, 9/16-18 UNF Radial Drain Port	

H Inlet port

NN	No inlet on body
-----------	------------------

I Outlet port

NN	No outlet on body
-----------	-------------------

J Ports Pos & Spec Body

NN	Std from catalogue
-----------	--------------------



K Seals

N	Standard high temperature seals
W	Standard high temperature seals without Dust Cover

L Screws

N	Rust protected screws
----------	-----------------------

M Set valves

XNN	No valve										
XA*	Standard relief valve with coil voltage 12 V DC, DT connector										
XB*	Standard relief valve with coil voltage 24 V DC, DT connector										
	<table border="1"> <tr> <td>X*F</td> <td rowspan="9">Select Pressure vs. Bypass flow requirements using the graph below. Three color curves represent three types of valves. Each valve is characterized by different nominal spring ranges.</td> </tr> <tr><td>X*I</td></tr> <tr><td>X*M</td></tr> <tr><td>X*O</td></tr> <tr><td>X*Q</td></tr> <tr><td>X*S</td></tr> <tr><td>X*U</td></tr> <tr><td>X*W</td></tr> <tr><td>X*Y</td></tr> </table>	X*F	Select Pressure vs. Bypass flow requirements using the graph below. Three color curves represent three types of valves. Each valve is characterized by different nominal spring ranges.	X*I	X*M	X*O	X*Q	X*S	X*U	X*W	X*Y
X*F	Select Pressure vs. Bypass flow requirements using the graph below. Three color curves represent three types of valves. Each valve is characterized by different nominal spring ranges.										
X*I											
X*M											
X*O											
X*Q											
X*S											
X*U											
X*W											
X*Y											
SA*	Flat curve valve with coil voltage 12 V DC, DT connector										
SB*	Flat curve valve with coil voltage 24 V DC, DT connector										
	<table border="1"> <tr> <td>S*O</td> <td rowspan="6"> </td> </tr> <tr><td>S*S</td></tr> <tr><td>S*W</td></tr> <tr><td>S*X</td></tr> <tr><td>S*W</td></tr> <tr><td>S*X</td></tr> </table>	S*O		S*S	S*W	S*X	S*W	S*X			
S*O											
S*S											
S*W											
S*X											
S*W											
S*X											

N Type of mark

N	Standard marking
A	Standard + customer code
Z	Without marking
*	Special customer marking

O Mark position

N	Std Marking position (on top)
A	Special Marking position on the bottom



Mounting flange and shaft options

Turolla offers two types of industry standard mounting flanges :

“02” :European, pilot Ø 80 mm [Dia 3.15 in], 4-bolts

“06” : SAE A, pilot Ø 82.55 mm [Dia 3.25 in], 2-bolts.

The table below shows order codes for each available mounting flange and shaft:



Shaft/Flange		Maximum torque			
Code	Description	Code 01 flange	Code 02 flange	Code 06 flange	Code 9Y flange
01BA	European, pilot Ø 36.5 mm [1.44 in], 4-bolts Taper 1:8, Key 4 – M12 X 1,25	150 Nm [1328 lbin]			
01FA	European, pilot Ø 36.5 mm [1.44 in], 4-bolts Parallel Ø 15mm [0.591 in], L 36,5 [1.44 in]	90 Nm [797 lbin]			
02AA	European, pilot Ø 80 mm [Dia 3.15 in], 4-bolts Taper 1:5, Key 3 – M12 x 1.25		140 N•m [1239 lb•in]		
06BA	SAE A, pilot Ø 82.55 mm [Dia 3.25 in], 2-bolts Taper 1:8, Key 4 – M12 x 1.25	-		150 N•m [1328 lb•in]	
06GB	SAE A, pilot Ø 82.55 mm [Dia 3.25 in], 2-bolts Parallel Ø 15.875 [Dia 0.625], L 50.8 [2]	-		80 N•m [708 lb•in]	
9YDB	Outrigger Bearing with dust cover - SAE A flange pilot Ø 82,55 [Dia 3.25 in] 2-bolts 1:8 Tapered shaft, Key 4 – M12 x 1.25	-			130 Nm [1151 lbin]

Spline configuration is not available for Group 2 fan drive motors. Other shaft options may exist. Contact your Turolla representative for availability.

! Caution

Shaft torque capability may limit allowable pressure. Torque ratings assume no external radial loading. Applied torque must not exceed these limits, regardless of stated pressure parameters. Maximum torque ratings are based on shaft torsional fatigue strength.



SGM2VC • 02AA dimensions

mm
[in]

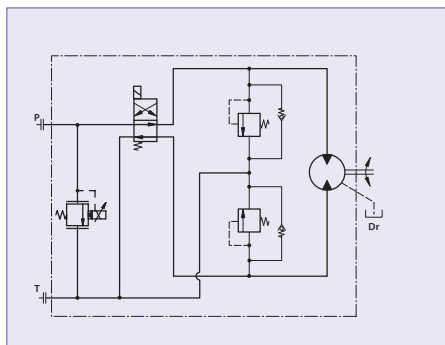
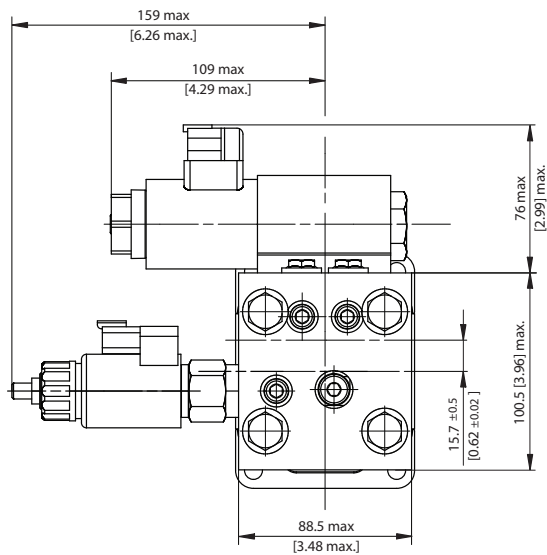
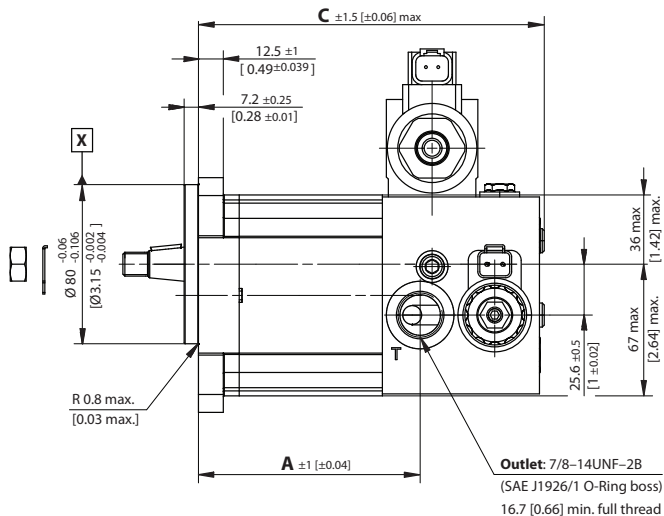
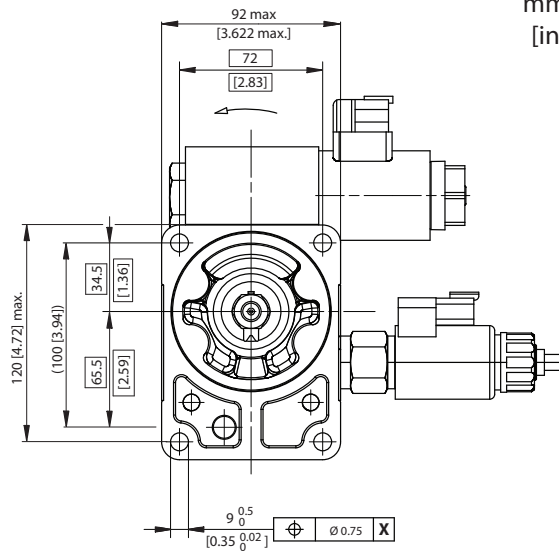
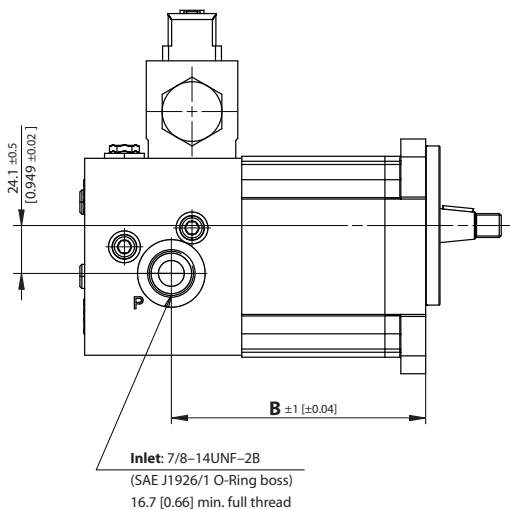

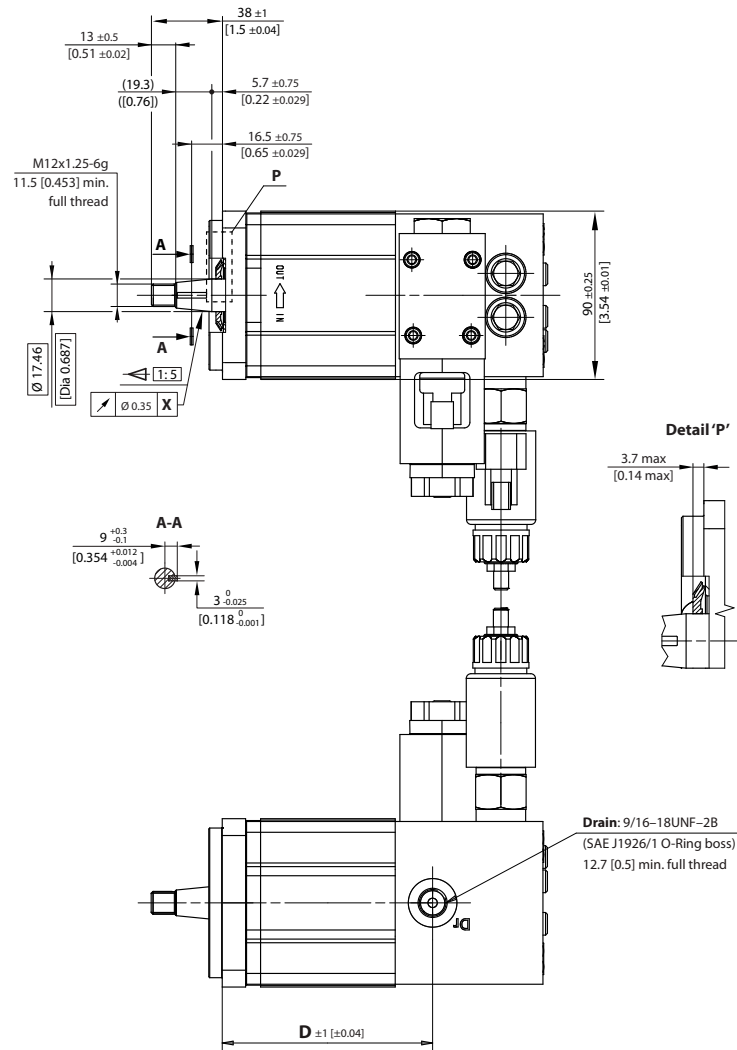

mm
[in]

SGM2VC – 02AA dimensions

Frame size	8,0	011	014	017	019	022	025	
Dimension	A	97.5 [3.84]	101.5 [4.0]	107.5 [4.23]	111.5 [4.39]	115.5 [4.55]	121.5 [4.78]	125.5 [4.94]
	B	114 [4.49]	118 [4.65]	124 [4.88]	128 [5.04]	132 [5.20]	138 [5.43]	142 [5.59]
	C	160 [6.30]	164 [6.46]	170 [6.69]	174 [6.85]	178 [7.0]	184 [7.24]	188 [7.40]
	D	98.5 [3.88]	102.5 [4.04]	108.5 [4.27]	112.5 [4.43]	116.5 [4.59]	122.5 [4.82]	126.5 [4.98]
Inlet/Outlet	7/8–14UNF–2B (SAE J1926/1 O-Ring boss); 16.7 [0.66] min. full thread							
Drain port	9/16–18UNF–2B (SAE J1926/1 O-Ring boss); 12.7 [0.5] min. full thread							

Model code example and maximum shaft torque

Flange/shaft	Model code example	Maximum shaft torque
02AA	SGM2VC/014LA02AARANNNNNNN/XASNN	140 N·m [1239 lb·in]

For further details on ordering, see [Model Code](#), pages 42 - 44.



SGM2VC • 06BA dimensions

mm
[in]

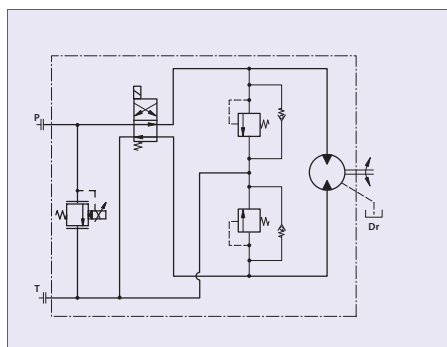
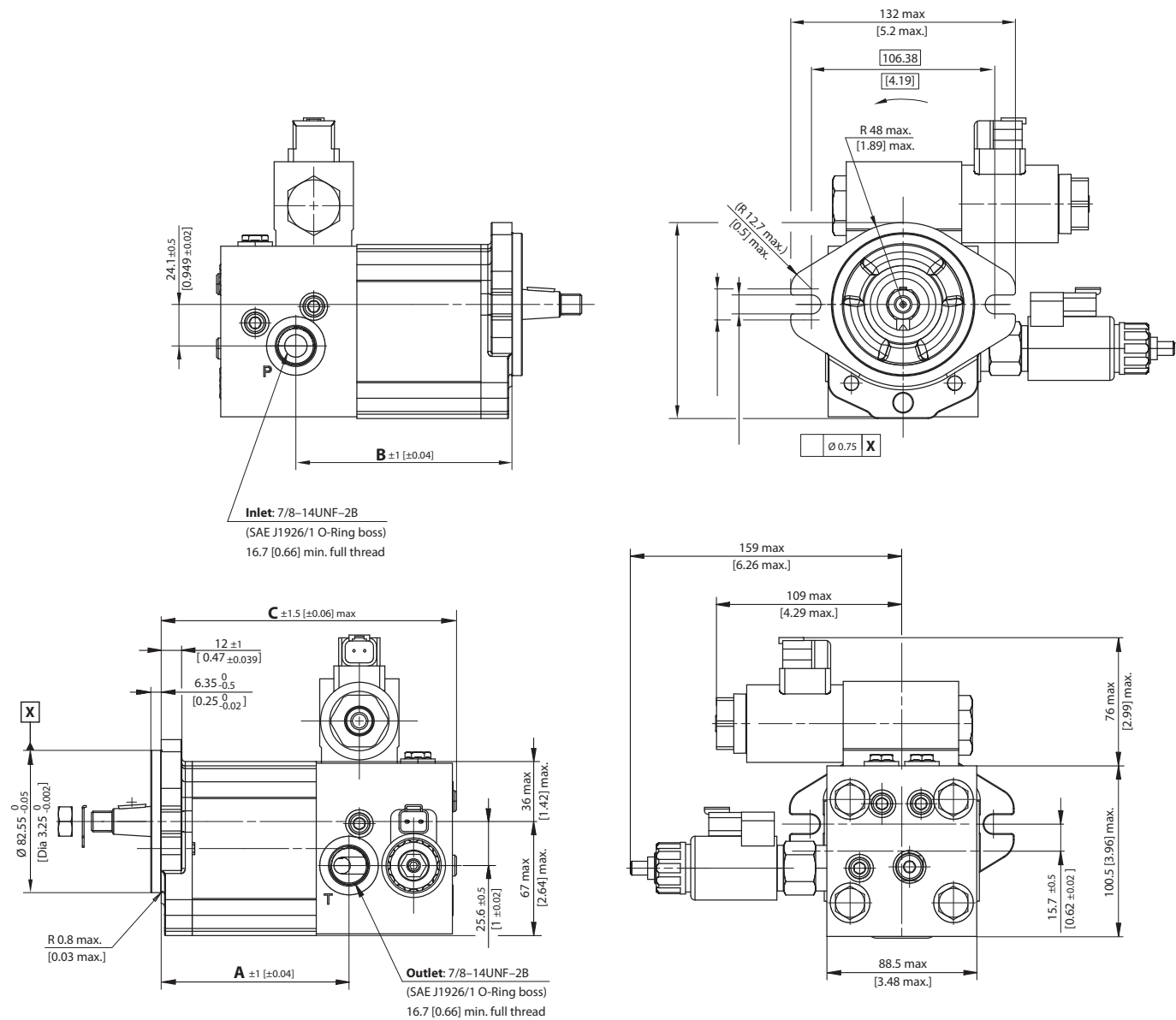

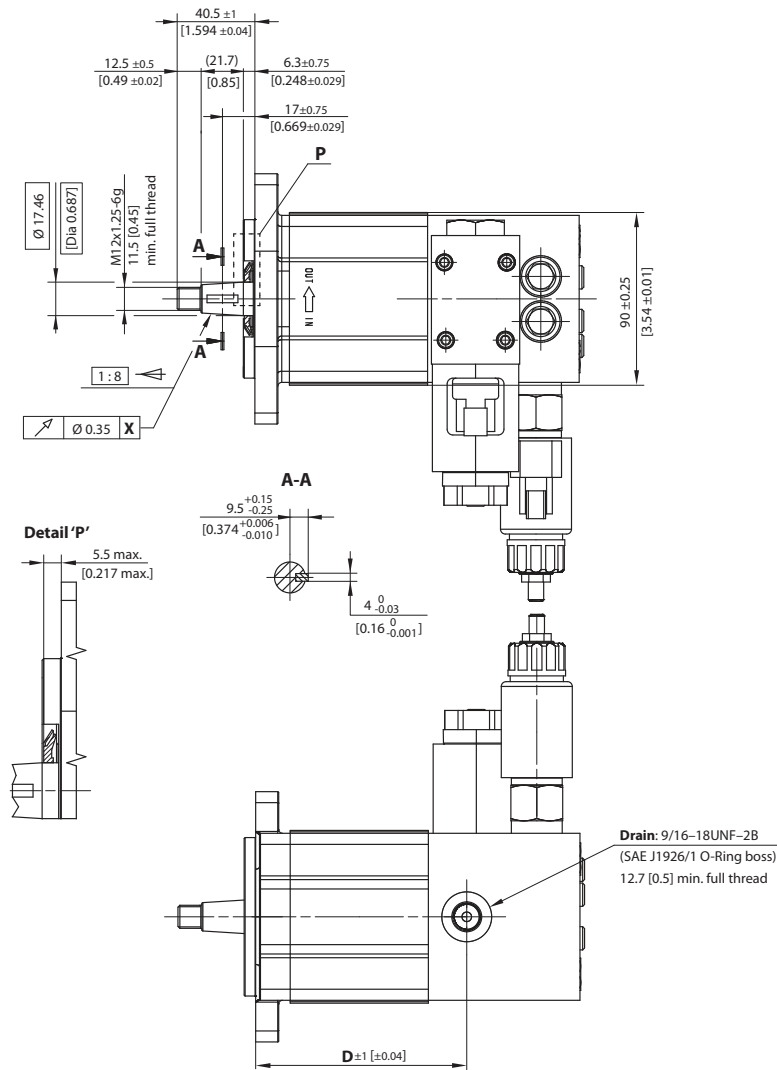

mm
[in]

SGM2VC – 06BA dimensions

Frame size	8,0	011	014	017	019	022	025	
Dimension	A	95 [3.74]	99 [3.90]	105 [4.13]	109 [4.29]	113 [4.45]	119 [4.69]	123 [4.84]
	B	111.4 [4.39]	115.4 [4.54]	121.4 [4.78]	125.4 [4.94]	129.4 [5.09]	135.4 [5.33]	139.4 [5.49]
	C	157.4 [6.20]	161.4 [6.35]	167.4 [6.59]	171.4 [6.75]	175.4 [6.90]	181.4 [7.14]	185.4 [7.30]
	D	96 [3.78]	100 [3.94]	106 [4.17]	110 [4.33]	114 [4.49]	120 [4.72]	124 [4.88]
Inlet/Outlet	7/8-14UNF-2B (SAE J1926/1 O-Ring boss); 16.7 [0.66] min. full thread							
Drain port	9/16-18UNF-2B (SAE J1926/1 O-Ring boss); 12.7 [0.5] min. full thread							

Model code example and maximum shaft torque

Flange/shaft	Model code example	Maximum shaft torque
06BA	SGM2VC/014LA06BARANNNNNNNN/XASNN	150 N·m [1328 lb·in]

For further details on ordering, see [Model Code](#), pages 42 - 44.



SGM2VC • 06GB dimensions

mm
[in]

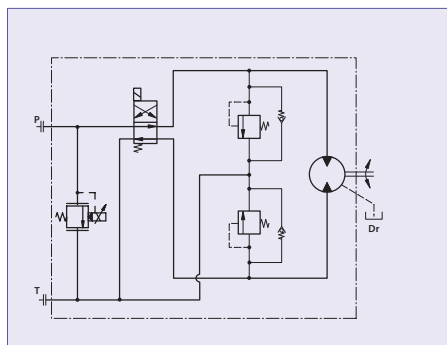
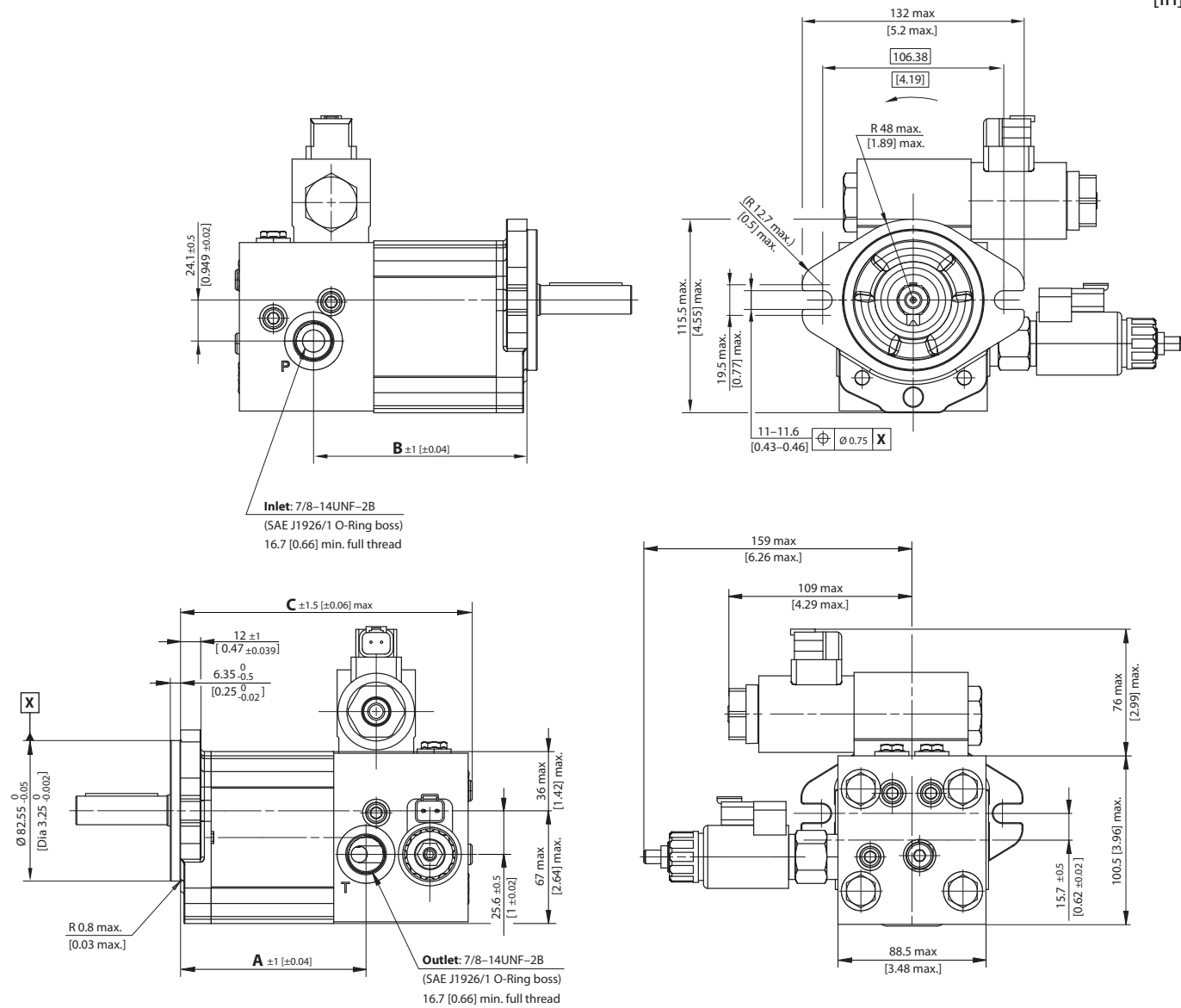

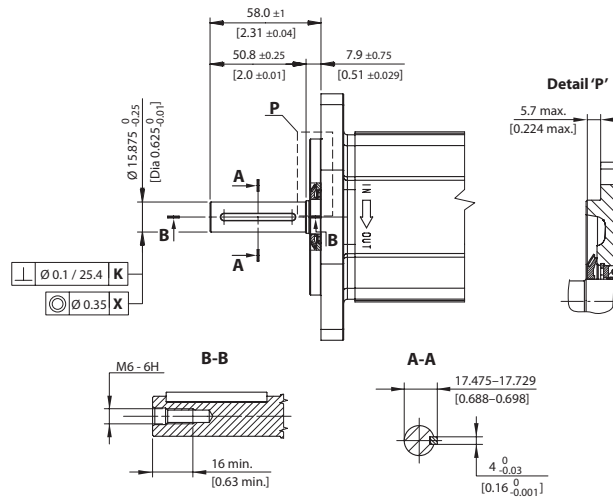

mm
[in]

SGM2VC – 06GB dimensions

Frame size	8,0	011	014	017	019	022	025	
Dimension	A	95 [3.74]	99 [3.90]	105 [4.13]	109 [4.29]	113 [4.45]	119 [4.69]	123 [4.84]
	B	111.4 [4.39]	115.4 [4.54]	121.4 [4.78]	125.4 [4.94]	129.4 [5.09]	135.4 [5.33]	139.4 [5.49]
	C	157.4 [6.20]	161.4 [6.35]	167.4 [6.59]	171.4 [6.75]	175.4 [6.90]	181.4 [7.14]	185.4 [7.30]
	D	96 [3.78]	100 [3.94]	106 [4.17]	110 [4.33]	114 [4.49]	120 [4.72]	124 [4.88]
Inlet/Outlet	7/8–14UNF–2B (SAE J1926/1 O-Ring boss); 16.7 [0.66] min. full thread							
Drain port	9/16–18UNF–2B (SAE J1926/1 O-Ring boss); 12.7 [0.5] min. full thread							

Model code example and maximum shaft torque

Flange/shaft	Model code example	Maximum shaft torque
06GB	SGM2VC/014RA06GBRANNNNNNN/SASNN	80 N·m [708 lb·in]

For further details on ordering, see [Model Code](#), pages 42 - 44.



Outrigger bearing

SGM2NC and SGM2YN dimensions

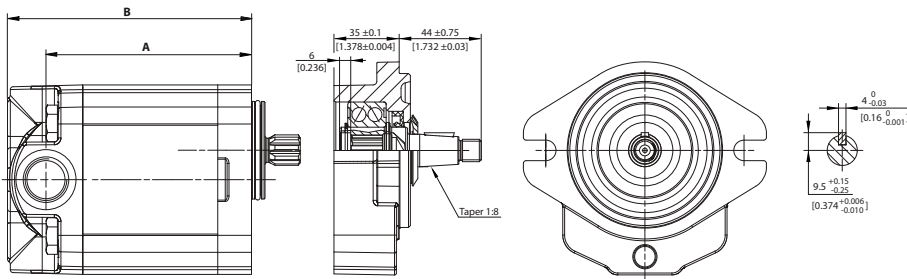

Frame size	8,0	011	014	017	019	022	025
A	95.5 [3.76]	99.5 [3.92]	105.5 [4.15]	109.5 [4.31]	113.5 [4.47]	119.5 [4.70]	123.5 [4.86]
B	116 [4.66]	120 [4.83]	126 [5.05]	130 [5.22]	134 [5.37]	140 [5.61]	144 [5.77]

SGM2VC dimensions

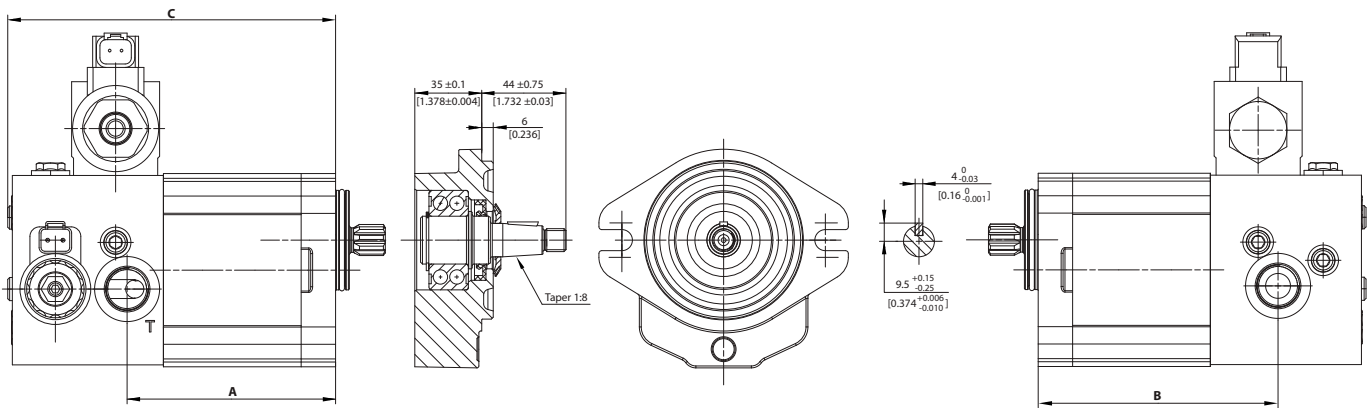

Frame size	8,0	011	014	017	019	022	025
A	95 [3.74]	99 [3.90]	105 [4.13]	109 [4.29]	113 [4.45]	119 [4.69]	123 [4.84]
B	111.4 [4.39]	115.4 [4.54]	121.4 [4.78]	125.4 [4.94]	129.4 [5.09]	135.4 [5.33]	139.4 [5.49]
C	157.4 [6.20]	161.4 [6.35]	167.4 [6.59]	171.4 [6.75]	175.4 [6.90]	181.4 [7.14]	185.4 [7.30]



GROUP 3 FAN DRIVE GEAR MOTORS

SGM3NC

Motor design

SGM3NC is Group 3 bidirectional fan drive motor with inlet/outlet on cast iron rear cover and axial drain line

Displacement range from 22.1 cm³/rev up to 44.1 cm³/rev [from 1.34 in³/rev up to 2.69 in³/rev].

Configurations include European and SAE flanges; taper 1:8, taper 1:5 and parallel Ø15.875 mm [Dia 0,62 in] shafts.

Outrigger bearing available as SAE A flange with taper shaft 1:8 and European flange with taper shaft 1:5.

SGM3NC

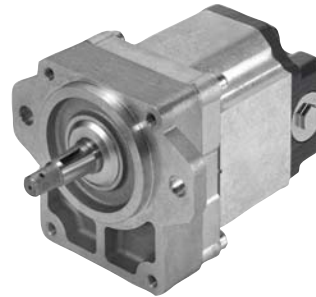

Technical data

Technical data for SGM3NC standard fan drive gear motors

Frame size		022	026	033	038	044
Displacement	cm ³ /rev [in ³ /rev]	22.1 [1.34]	26.2 [1.60]	33.1 [2.02]	37.9 [2.31]	44.1 [2.69]
Peak pressure	bar [psi]	270 [3916]	270 [3916]	270 [3916]	270 [3916]	270 [3916]
Rated pressure		250 [3626]	250 [3626]	250 [3626]	250 [3626]	250 [3626]
Back pressure		250 [3626]	250 [3626]	250 [3626]	250 [3626]	250 [3626]
Maximum speed	min ⁻¹ (rpm)	2500	2500	2500	2500	2300
Minimum speed		800	800	800	800	800
Weight	kg [lb]	8.62 [19.0]	8.72 [19.23]	8.82 [19.45]	8.88 [19.58]	9.02 [19.89]
Moment of inertia of rotating components	x 10 ⁻⁶ kg·m ² [x 10 ⁻⁶ lbf·ft ²]	198 [4699]	216 [5126]	246 [5838]	267.2 [6341]	294.2 [6981]



Product code

Model code

A	B	C	D	E	F	G	H	I	J	K	L	M	N	O
□□□□□□□□	□□□□	□	□	□□	□□	□□	□□	□□	□□	□	□	□□□□	□	□

A Family

SGM3NC	Gr3 Fan Drive Bidirec.Motor-External Axial Drain
SGM3GC	Gr3 Fan Drive Unidirec Motor+Anticav.Check valve

B Displacement

022	22,1 cc	038	37,9 cc
026	26,2 cc	044	44,1 cc
033	33,1 cc		

C Rotation

B	Bidirectional
L	Left rotation
R	Right rotation

D Project version

A	High Temperature sealing Dust protector Rust protected screws
----------	---------------------------------------------------------------------

E Mounting flange

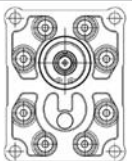
01	European 01 flange, Pilot Ø50,8+4 holes (98,4x128,1)	
-----------	------------------------------------------------------------	-------------------------------------------------------------------------------------

07	SAE B-flange pilot Ø101,6 +2 holes	
-----------	---------------------------------------	-------------------------------------------------------------------------------------

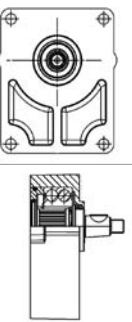
91	Outrigger bearing flange 01 -Taper 1:8 M14x1,5 key 4x7,5	
-----------	-------------------------------------------------------------	-------------------------------------------------------------------------------------

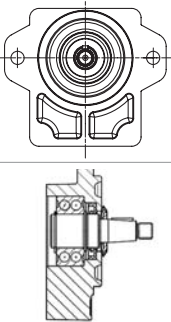
9Y	Outrigger Bearing with dust cover - SAE B flange pilot Ø101,6 [Dia 4 in] 2-bolts - 1:8 Tapered shaft thread 5/8-18UNF, Key 6,375mm [0.25 in]	
-----------	----------------------------------------------------------------------------------------------------------------------------------------------------------	---------------------------------------------------------------------------------------

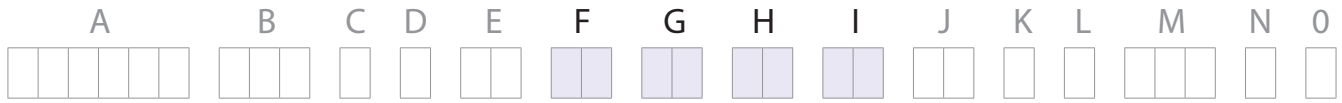

F Drive gear

BA	Taper 1:8-M14x1,5-Key 4 (for Mounting Flange 01+Outrigger Bearing 91) Special	
-----------	----------------------------------------------------------------------------------------	--

BP	Taper 1:8-5/8-18UNF-2A-Key 6,375 with NUT & WASHER (for SAE B flange) Special	
-----------	----------------------------------------------------------------------------------------	--

BC	Taper 1:8-5/8-18UNF-2A-Key 6,375	
-----------	-------------------------------------	--

GB	Parallel Ø22,225xL25,4-Key 6,375x6,375x25,4+thd hole:1/4-20UNC-2B	
-----------	-------------------------------------------------------------------------	--

G Rear cover

C6	Cast Iron cover with 1-1/16 12 UN In-Out Ports - 9/16-18 UNF Axial Drain (idler gear side)	
-----------	-----------------------------------------------------------------------------------------------------	--

CZ	Cast Iron cover with 1-1/16 12 UN In-Out Ports - 9/16-18 UNF Radial Drain (shaft side)	
-----------	----------------------------------------------------------------------------------------------	--

CX	Cast Iron cover with 1-1/16 12 UN In-Out Ports - 9/16-18 UNF Radial Drain (idler gear side)	
-----------	------------------------------------------------------------------------------------------------------	--

H Inlet port

NN	No inlet on body
-----------	------------------

I Outlet port

NN	No outlet on body
-----------	-------------------



J Ports Pos & Spec Body

NN	Std from catalogue
----	--------------------

K Seals

N	Standard high temperature seals
---	---------------------------------

L Screws

N	Standard Rust protected screws
---	--------------------------------

M Set valves

NNN	No Valve
-----	----------

N Type of mark

N	Standard marking
A	Standard + customer code
Z	Without marking
*	Special customer marking

O Mark position

N	Std Marking position (on top)
A	Special Marking position on the bottom



Mounting flange and shaft options

Turolla offers two types of industry standard mounting flanges :

“07” : SAE B, pilot Ø 101.6 mm [Dia 4 in], 2-bolts

“9Y” : Outrigger Bearing with dust cover - SAE B flange pilot Ø101,6 [Dia 4 in] 2-bolts - 1:8 Tapered shaft thread 5/8-18UNF, Key 6,375mm [0.25 in]

The table below shows order codes for each available mounting flange and shaft:

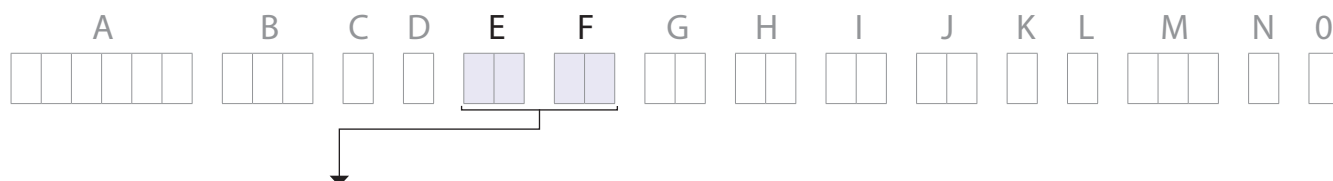

Shaft/Flange		Maximum torque		
Code	Description	Code 07 flange	Code 91 flange	Code 9Y flange
07BC	SAE B, pilot Ø 101.6 mm [Dia 4 in], 2-bolts Taper 1:8, 5/8-18UNF, Key 6.375 [0.25]	300 Nm [2655 lbin]		
07BP	SAE B, pilot Ø 101.6 mm [Dia 4 in], 2-bolts Taper 1:8, 5/8-18UNF, Key 6.375 [0.25]+ washer and nut	300 N•m [2655 lb•in]		
07GB	SAE B, pilot Ø 101.6 mm [Dia 4 in], 2-bolts Parallel drive Ø 22.225 [Dia 0.875], L = 25.4 [1] ,Key 6.375 [0.25]	230 N•m [2036 lb•in]		
91BA	Outrigger Bearing without dust cover – European pilot Ø 50.8 mm [Dia 2.0 in] 4-bolt 1:8 Tapered shaft thread M14x1,5 key 4x7,5		350 Nm [3097 lbin]	
9YDA	Outrigger Bearing with dust cover – SAE B flange pilot Ø101,6 [Dia 4 in] 2-bolts 1:8 Tapered shaft thread 5/8-18UNF, Key 6,375mm [0.25 in]			290 Nm [2566 lbin]

Spline configuration is not available for Group 3 fan drive motors. Other shaft options may exist. Contact your Turolla representative for availability.

! Caution

Shaft torque capability may limit allowable pressure. Torque ratings assume no external radial loading. Applied torque must not exceed these limits, regardless of stated pressure parameters. Maximum torque ratings are based on shaft torsional fatigue strength.



SGM3NC • 07BC dimensions

mm
[in]

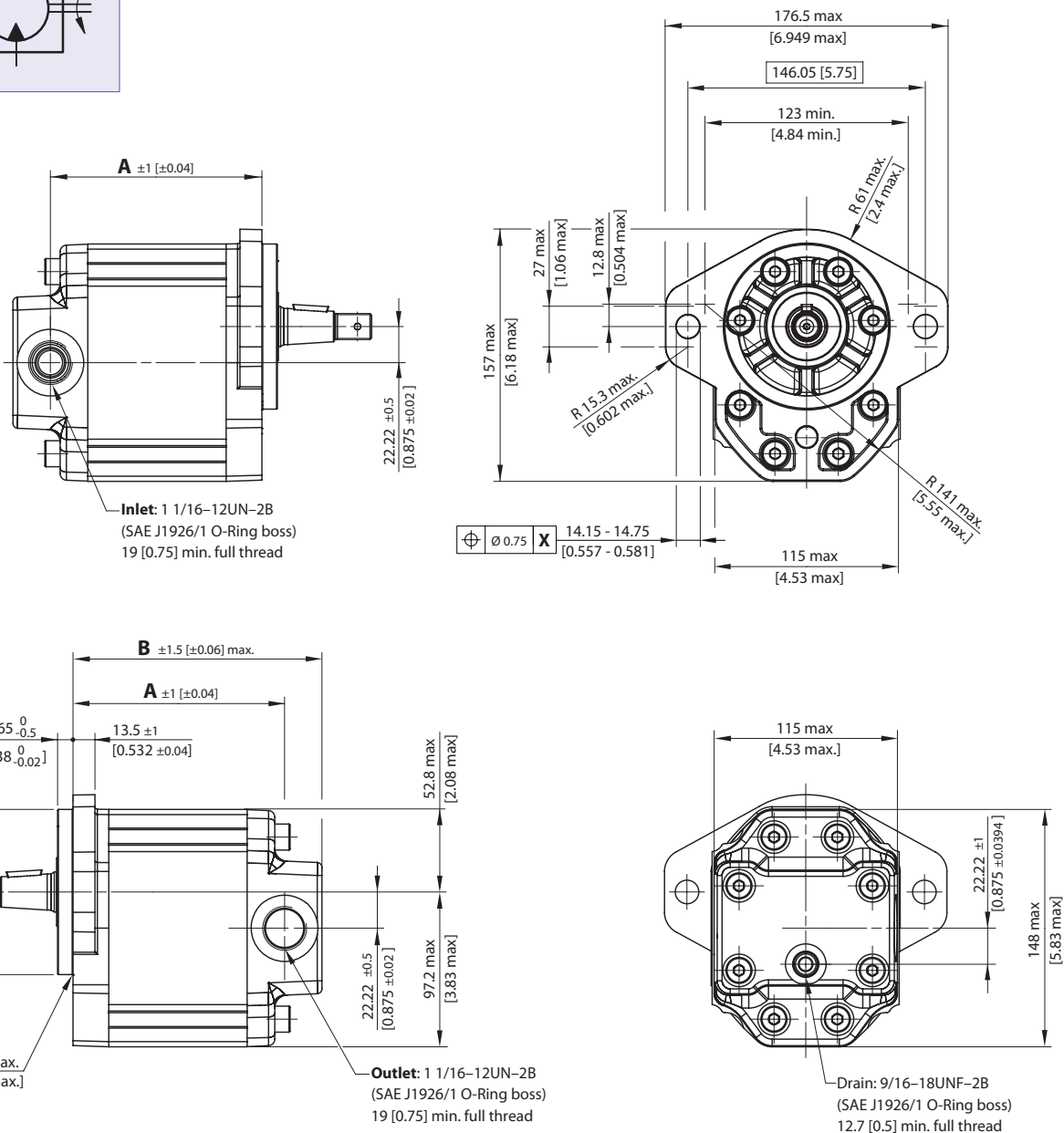
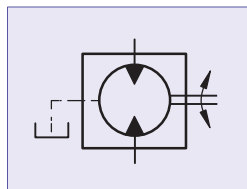

SGM3NC – 07BC dimensions

Frame size		022	026	033	038	044
Dimension	A	127.1 [5.04]	130.1 [5.12]	135.1 [5.32]	138.6 [5.46]	143.1 [5.63]
	B	150.1 [5.91]	153.1 [6.03]	158.1 [6.22]	161.6 [6.36]	166.1 [6.54]
Inlet/Outlet		1-1/16-12UN-2B (SAE J1925/1, O-Ring boss); 19 [0.748] min. full thread				
Drain port		9/16-18UNF-2B (SAE J1925/1, O-Ring boss); 12.7 [0.5] min. full threads				

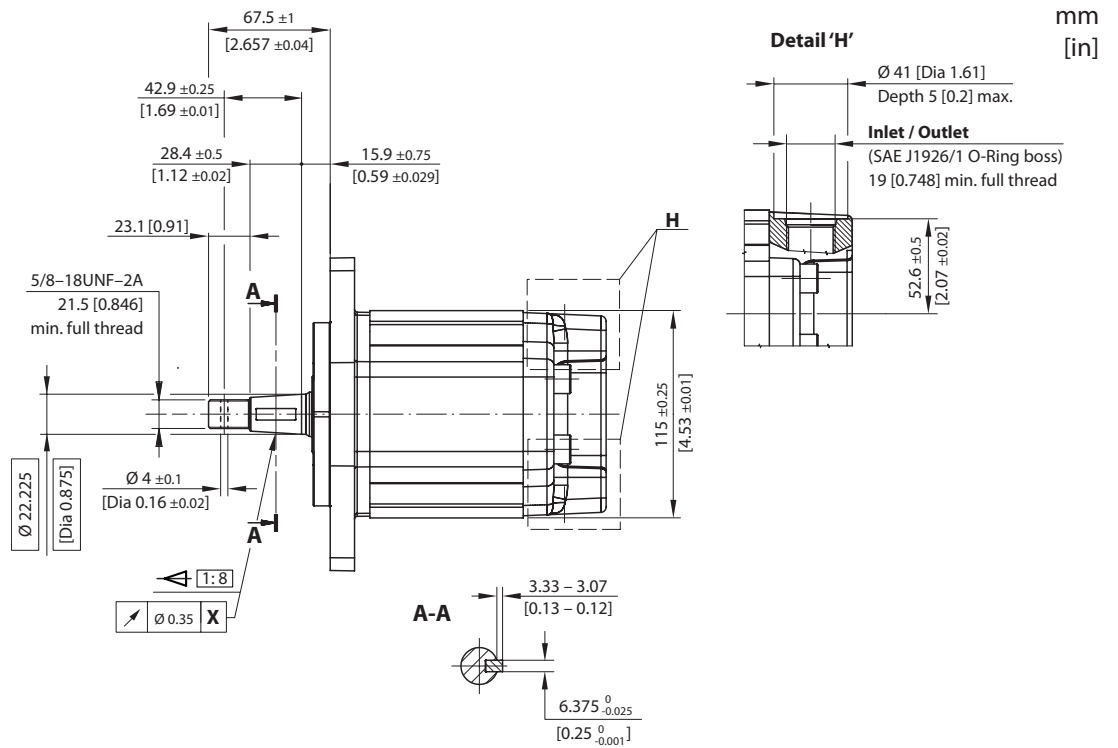

Model code example and maximum shaft torque

Flange/shaft	Model code example	Maximum shaft torque
07BC	SGM3NC/026BA07BCC6NNNNNNNN/NNNNN	300 N•m [2655 lb•in]

For further details on ordering, see [Model Code](#), page 54 - 56.



SGM3NC • 07GB dimensions

mm
[in]

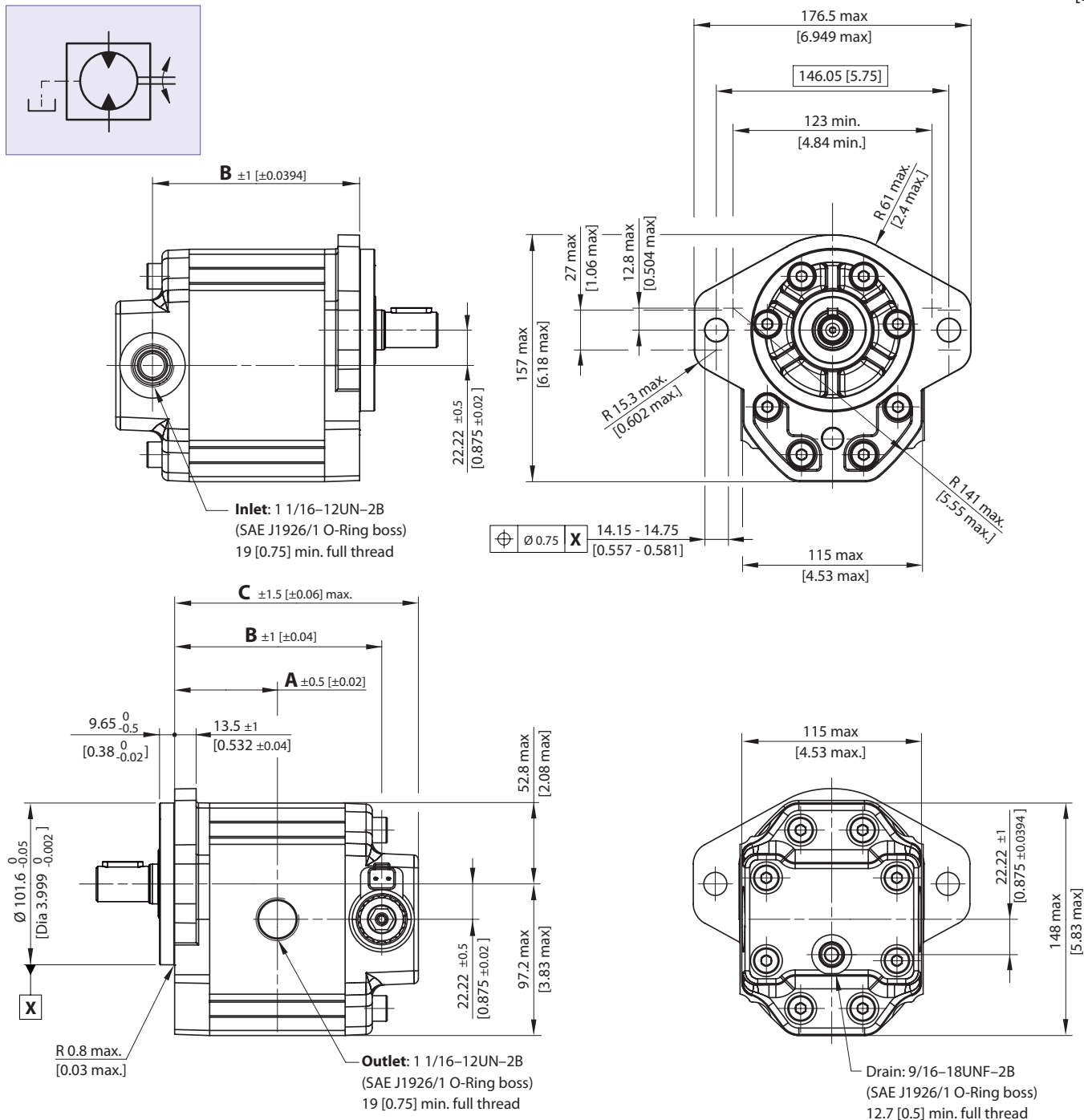

SGM3NC – 07GB dimensions

Frame size		022	026	033	038	044
Dimension	A	127.1 [5.04]	130.1 [5.12]	135.1 [5.32]	138.6 [5.46]	143.1 [5.63]
	B	150.1 [5.91]	153.1 [6.03]	158.1 [6.22]	161.6 [6.36]	166.1 [6.54]
Inlet/Outlet		1-1/16-12UN-2B (SAE J1925/1, O-Ring boss); 19 [0.748] min. full thread				
Drain port		9/16-18UNF-2B (SAE J1925/1, O-Ring boss); 12.7 [0.5] min. full threads				

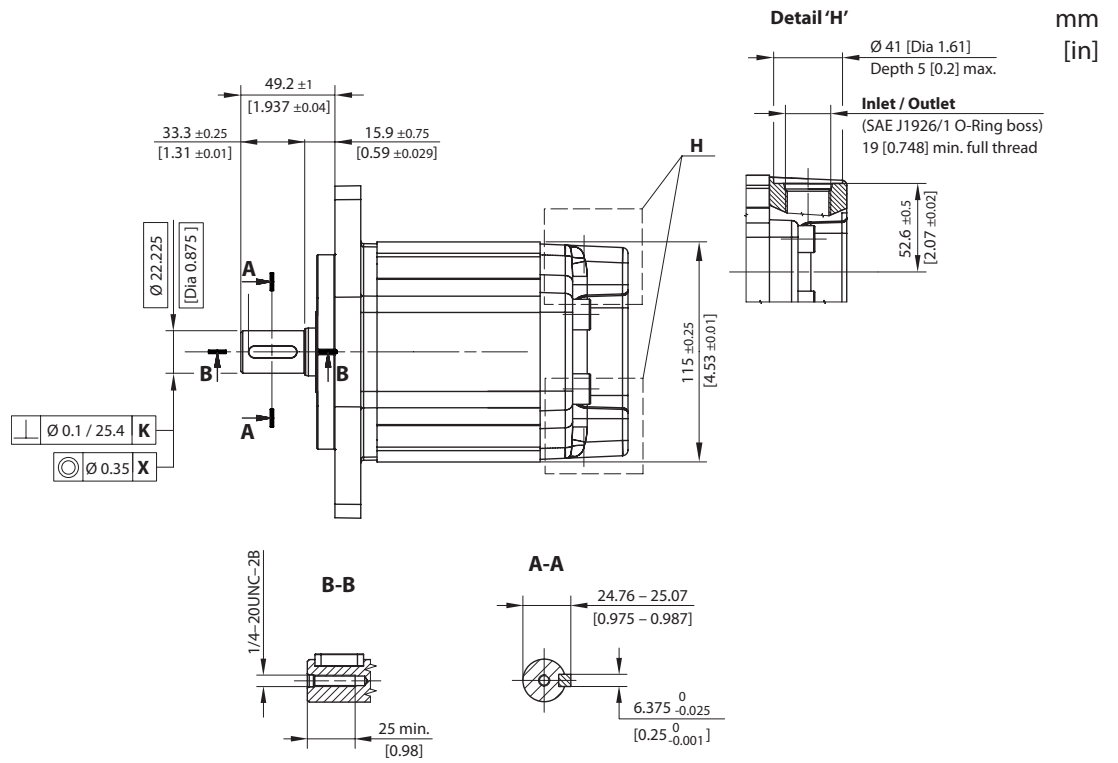

Model code example and maximum shaft torque

Flange/drive gear	Model code example	Maximum shaft torque
07GB	SGM3NC/026BA07GBC6NNNNNNNN/NNNNN	230 N·m [2036 lb·in]

For further details on ordering, see [Model Code](#), page 54 - 56.



GROUP 3 FAN DRIVE GEAR MOTORS SGM3YN

Motor design

SGM3YN is Group 3 fan drive motor with inlet on rear cover and outlet on body. Integrated proportional relief valve, anti-cavitation check valve and axial drain line.

Displacement range from 22.1 cm³/rev up to 44.1 cm³/rev [from 1.34 in³/rev up to 2.69 in³/rev].

Configurations include European and SAE flanges; taper 1:8, taper 1:5 and parallel Ø15.875 mm [Dia 0,62 in] shafts.

SGM3YN

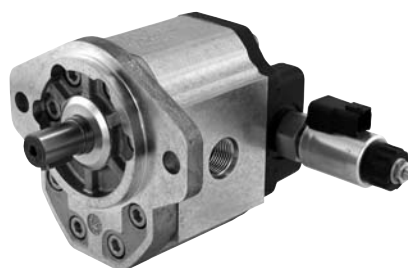

Outrigger bearing available as SAE A flange with taper shaft 1:8 and European flange with taper shaft 1:5.

Technical data

Technical data for SGM3YN standard fan drive gear motors

Frame size		022	026	033	038	044
Displacement	cm ³ /rev [in ³ /rev]	22.1 [1.34]	26.2 [1.60]	33.1 [2.02]	37.9 [2.31]	44.1 [2.69]
Peak pressure	bar [psi]	270 [3916]	270 [3916]	270 [3916]	270 [3916]	270 [3916]
Rated pressure		250 [3626]	250 [3626]	250 [3626]	250 [3626]	250 [3626]
Back pressure		150 [2176]	150 [2176]	150 [2176]	150 [2176]	150 [2176]
Maximum speed	min ⁻¹ (rpm)	2500	2500	2500	2500	2300
Minimum speed		800	800	800	800	800
Weight	kg [lb]	8.62 [19.0]	8.72 [19.23]	8.82 [19.45]	8.88 [19.58]	9.02 [19.89]
Moment of inertia of rotating components	x 10 ⁻⁶ kg·m ² [x 10 ⁻⁶ lbf·ft ²]	198 [4699]	216 [5126]	246 [5838]	267.2 [6341]	294.2 [6981]



Electro proportional relief valve standard

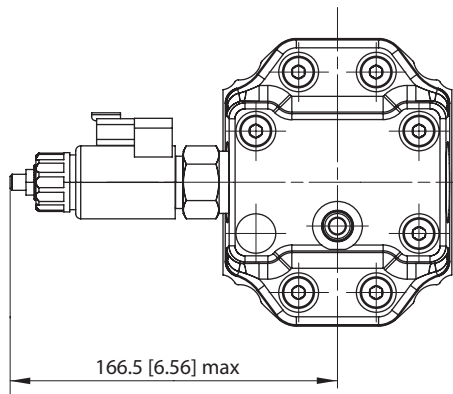

Electrical connectors	Deutsch DT 04-2P connectors (Protection rate IP 69K DIN 40050)
Electrical supply to EH valve	0 to 1.1 A @ 12 V DC, with coil resistance of 7.2 Ω @ 20 °C [68 °F] 0 to 0.55 A @ 24 V DC, with coil resistance of 28.8 Ω @ 20 °C [68 °F]
PWM frequency	from 100 to 200 Hz

Electro proportional relief valve flat curve

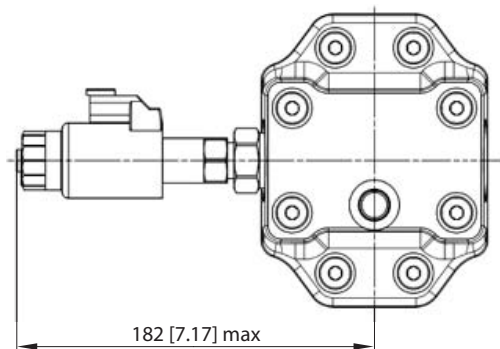

Electrical connectors	Deutsch DT 04-2P connectors (Protection rate IP 69K DIN 40050)
Electrical supply to EH valve	0 to 1.1 A @ 12 V DC, with coil resistance of 6.4 Ω @ 20 °C [68 °F] 0 to 0.55 A @ 24 V DC, with coil resistance of 26.2 Ω @ 20 °C [68 °F]
PWM frequency	from 100 to 250 Hz



Product code

Model code

A	B	C	D	E	F	G	H	I	J	K	L	M	N	O

A Family

SGM3YN	Gr3 Fan Drive Motor with Proportional Pressure Valve, Axial Drain
SGM3YL	Gr3 Fan Drive Motor with Proportional Pressure Valve, Radial Drain

B Displacement

022	22,1 cc	038	37,9 cc
026	26,2 cc	044	44,1 cc
033	33,1 cc		

C Rotation

L	Left rotation
R	Right rotation

D Project version

A	High Temperature sealing Dust protector Rust protected screws
----------	---------------------------------------------------------------------

E Mounting flange

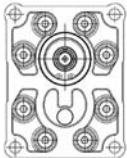
01	European 01 flange, Pilot Ø50,8+4 holes (98,4x128,1)	
-----------	------------------------------------------------------------	-------------------------------------------------------------------------------------

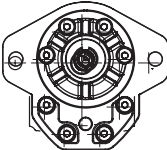
07	SAE B-flange pilot Ø101,6 +2 holes	
-----------	---------------------------------------	-------------------------------------------------------------------------------------

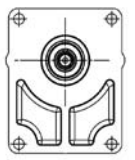
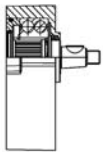
91	Outrigger bearing flange 01 Taper 1:8 M14x1,5 key 4x7,5	 
-----------	------------------------------------------------------------	----------------------------------------------------------------------------------------------------------------------------------------------------------------------------

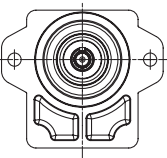
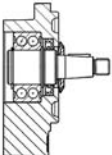
9Y	Outrigger Bearing with dust cover - SAE B flange pilot Ø101,6 [Dia 4 in] 2-bolts 1:8 Tapered shaft thread 5/8-18UNF, Key 6,375mm [0.25 in]	 
-----------	-----------------------------------------------------------------------------------------------------------------------------------------------------------	--------------------------------------------------------------------------------------------------------------------------------------------------------------------------------



F Drive gear

BA	Taper 1:8-M14x1,5-Key 4 (for Mounting Flange 01+Outrigger Bearing 91) Special	
-----------	-------------------------------------------------------------------------------	--

BP	Taper 1:8-5/8-18UNF-2A-Key 6,375 with NUT & WASHER (for SAE B flange) Special	
-----------	-------------------------------------------------------------------------------	--

BC	Taper 1:8-5/8-18UNF-2A-Key 6,375	
-----------	----------------------------------	--

GB	Parallel Ø22,225xL25,4-Key 6,375x6,375x25,4+thd hole:1/4-20UNC-2B	
-----------	-------------------------------------------------------------------	--

G Rear cover

Y6	Cast Iron cover with 1-1/16 12 UN In Port - 9/16-18 UNF Axial Drain (idler gear side)	
-----------	---------------------------------------------------------------------------------------	--

Yx	Cast Iron cover with 1-1/16 12 UN In Port - 9/16-18 UNF Radial Drain (shaft side)	
-----------	-----------------------------------------------------------------------------------	--

Y4	Cast Iron cover with 1-1/16 12 UN In Port - 9/16-18 UNF Radial Drain (idler gear side)	
-----------	----------------------------------------------------------------------------------------	--

H Inlet port

NN	No inlet on body
-----------	------------------



I Outlet port

A3	25x26,19x52,37x3/8-16UNC		F5	BSP 3/4 GAS	
BB	27x55xM8		F6	BSP 1 GAS	
C7	20x40xM8		F7	BSP 1-1/4 GAS	
CA	27x51xM10		H8	M27x2-ISO6149	
E6	1-1/16-12UN		M5	25x52,37x26,19xM10	
E8	1-5/16-12UN		M6	31x30,18x58,72xM10	
E9	1-5/8-12UN		M7	37,5x35,71x69,85xM12	
EI	1-7/8-12UN				

J Ports Pos & Spec Body

NN	Std from catalogue
ZZ	Port type Bx-Bx in the center of the body - option

K Seals

N	Standard high temperature seals
----------	---------------------------------

L Screws

N	Standard Rust protected screws
----------	--------------------------------



A	B	C	D	E	F	G	H	I	J	K	L	M	N	O

M Set valves

XNN	No valve									
XA*	Standard relief valve with coil voltage 12 V DC, DT connector									
XB*	Standard relief valve with coil voltage 24 V DC, DT connector									
<table border="1"> <tr><td>X*F</td></tr> <tr><td>X*I</td></tr> <tr><td>X*M</td></tr> <tr><td>X*O</td></tr> <tr><td>X*Q</td></tr> <tr><td>X*R</td></tr> <tr><td>X*S</td></tr> <tr><td>X*U</td></tr> <tr><td>X*W</td></tr> </table>	X*F	X*I	X*M	X*O	X*Q	X*R	X*S	X*U	X*W	<p>Select Pressure vs. Bypass flow requirements using the graph.</p> <p>Three color curves represent three types of valves.</p> <p>Each valve is characterized by different nominal spring ranges.</p>
X*F										
X*I										
X*M										
X*O										
X*Q										
X*R										
X*S										
X*U										
X*W										
SA*	Flat curve valve with coil voltage 12 V DC, DT connector									
SB*	Flat curve valve with coil voltage 24 V DC, DT connector									
<table border="1"> <tr><td>S*O</td></tr> <tr><td>S*S</td></tr> <tr><td>S*W</td></tr> <tr><td>S*X</td></tr> </table>	S*O	S*S	S*W	S*X	<p>Select Pressure vs. Bypass flow requirements using the graph.</p> <p>Each valve is characterized by different nominal spring ranges.</p>					
S*O										
S*S										
S*W										
S*X										

N Type of mark

N	Standard marking
A	Standard + customer code
Z	Without marking
*	Special customer marking

O Mark position

N	Std Marking position (on top)
A	Special Marking position on the bottom



SGM3YN • 07BC dimensions

mm
[in]

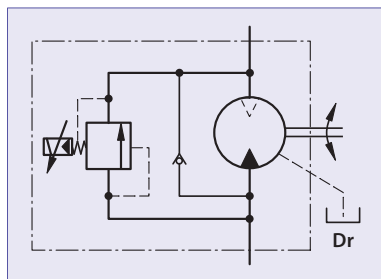
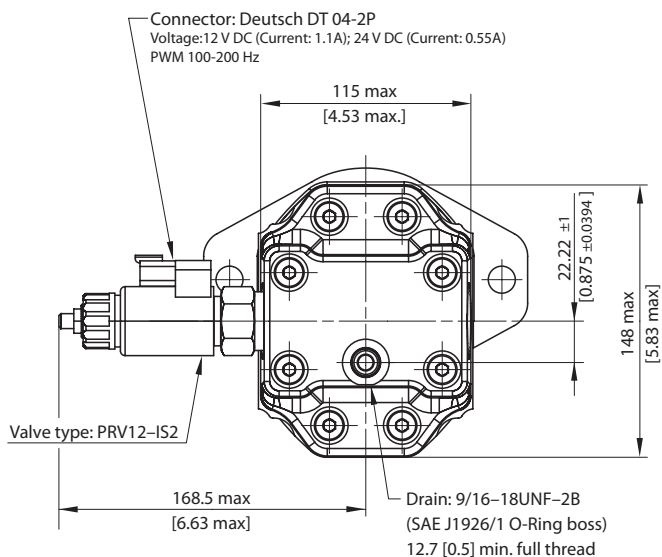
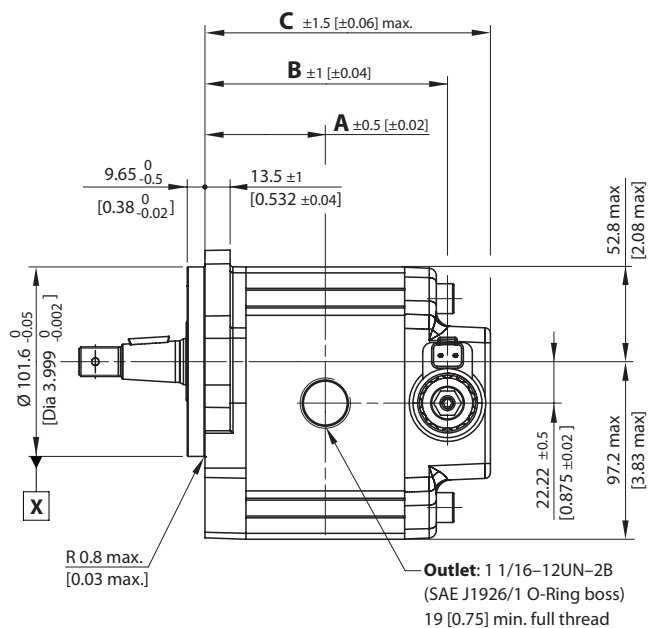
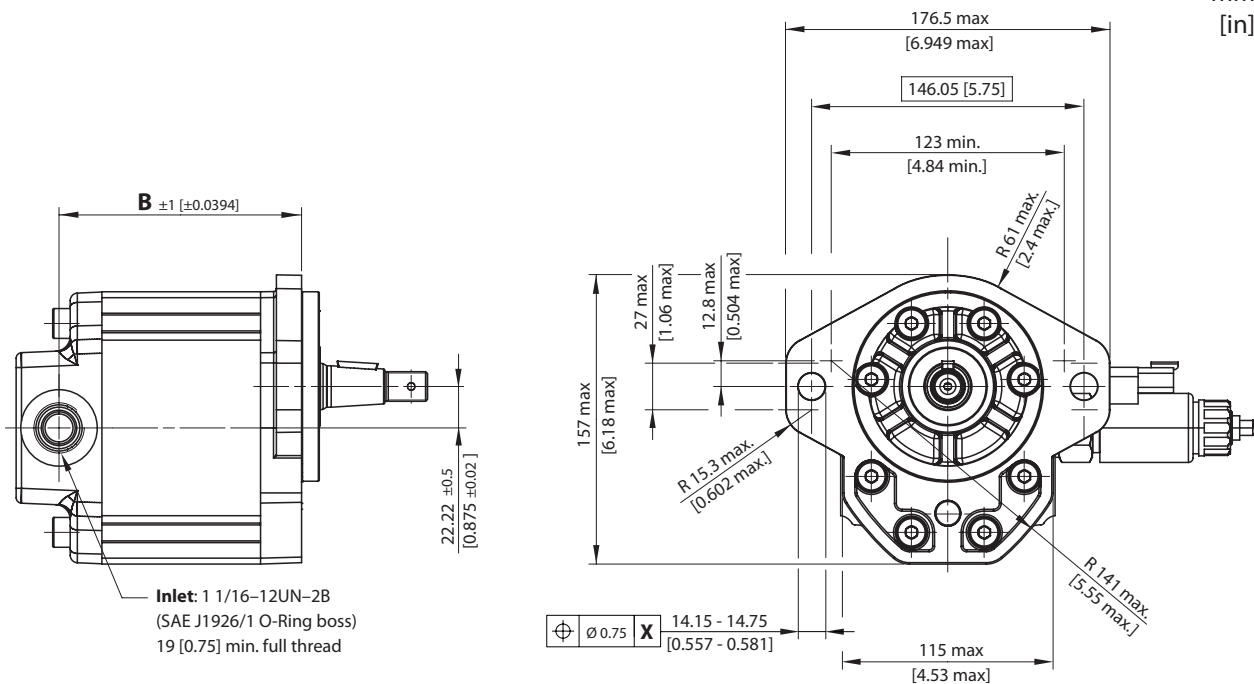

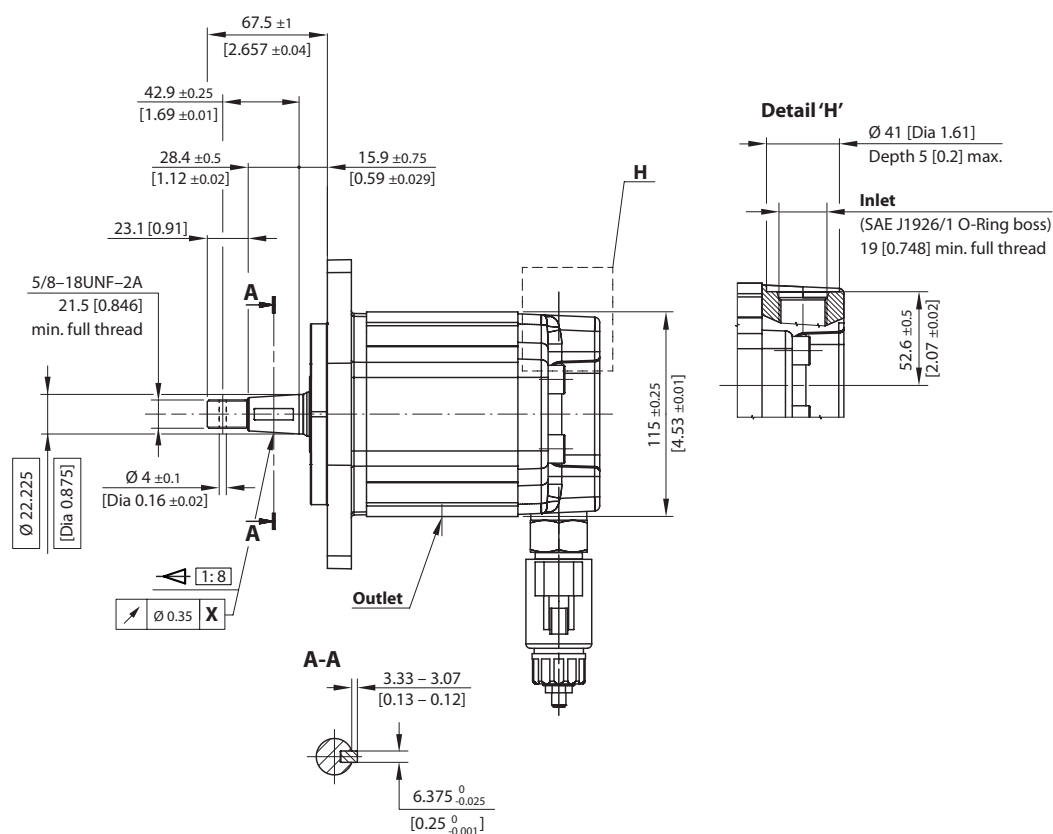

mm
[in]

SGM3YN – 07BC dimensions

Frame size	022	026	033	038	044
A	63 [2.48]	64.5 [2.54]	67 [2.64]	68.8 [2.71]	71 [2.8]
B	127.1 [5.04]	130.1 [5.12]	135.1 [5.32]	138.6 [5.46]	143.1 [5.63]
C	150.1 [5.91]	153.1 [6.03]	158.1 [6.22]	161.6 [6.36]	166.1 [6.54]
Inlet/Outlet	1-1/16-12UN-2B (SAE J1925/1, O-Ring boss); 19 [0.748] min. full thread				
Drain port	9/16-18UNF-2B (SAE J1925/1, O-Ring boss); 12.7 [0.5] min. full threads				

Model code example and maximum shaft torque

Flange/shaft	Model code example	Maximum shaft torque
07BC	SGM3YN/033LA07BCY6NNE6NNNN/XNNNN	300 N·m [2655 lb·in]

For further details on ordering, see [Model Code](#), pages 64 - 67.



SGM3YN • 07GB dimensions

mm
[in.]

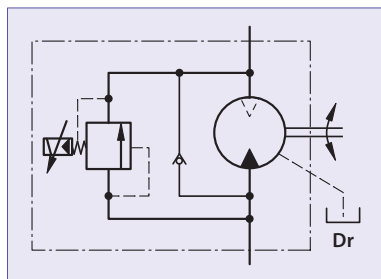
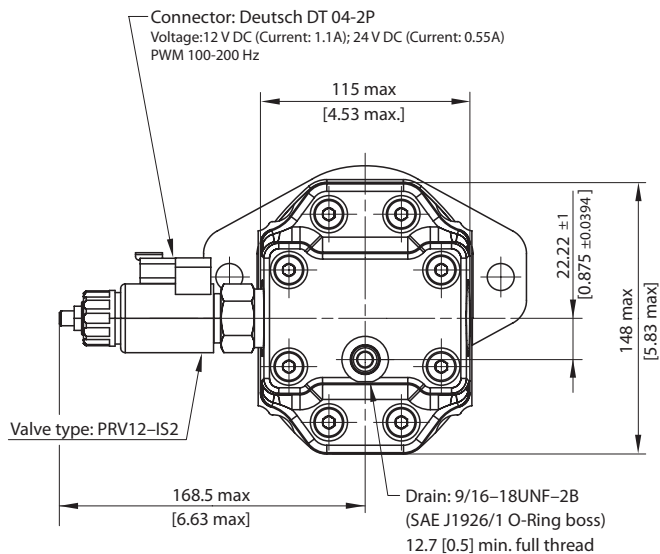
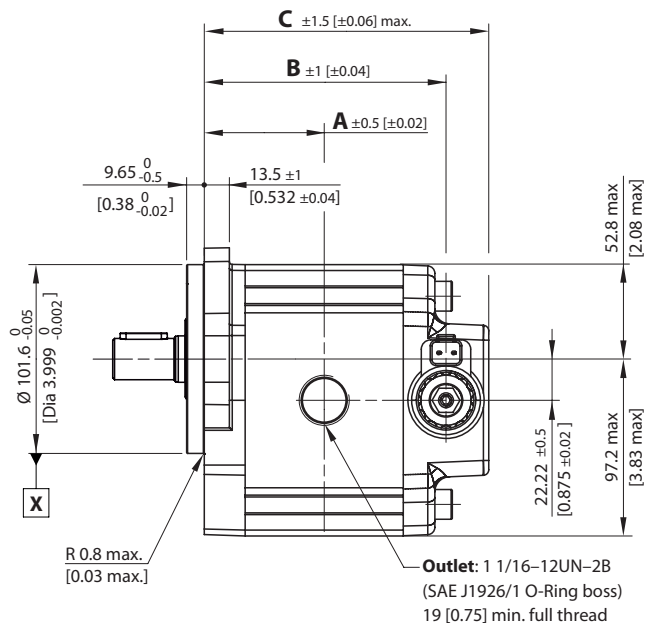
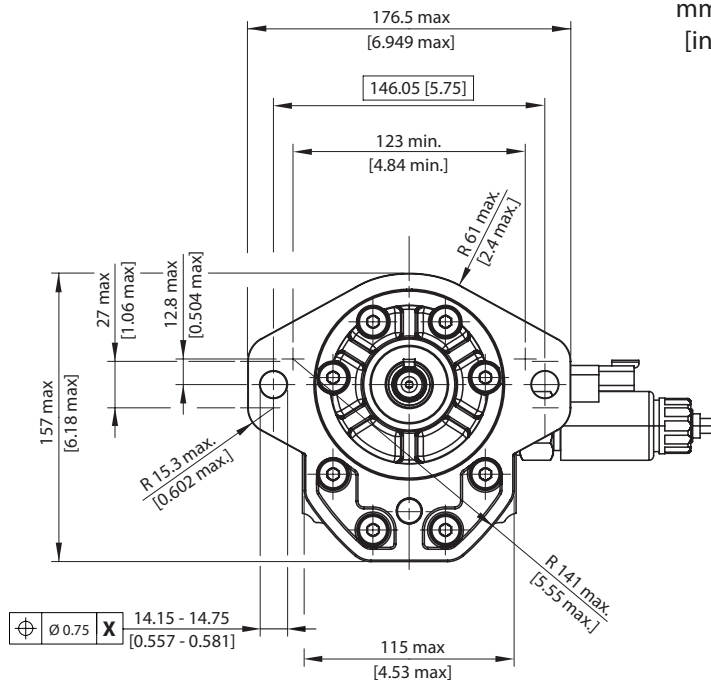
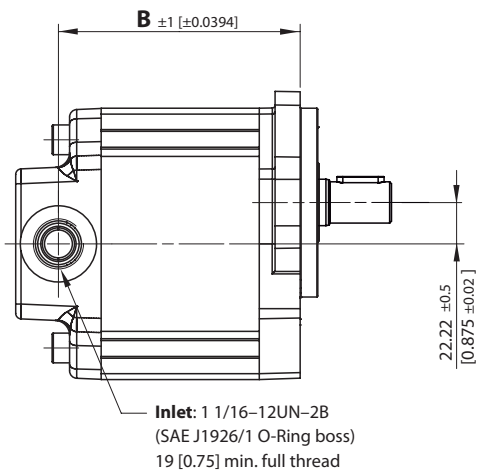

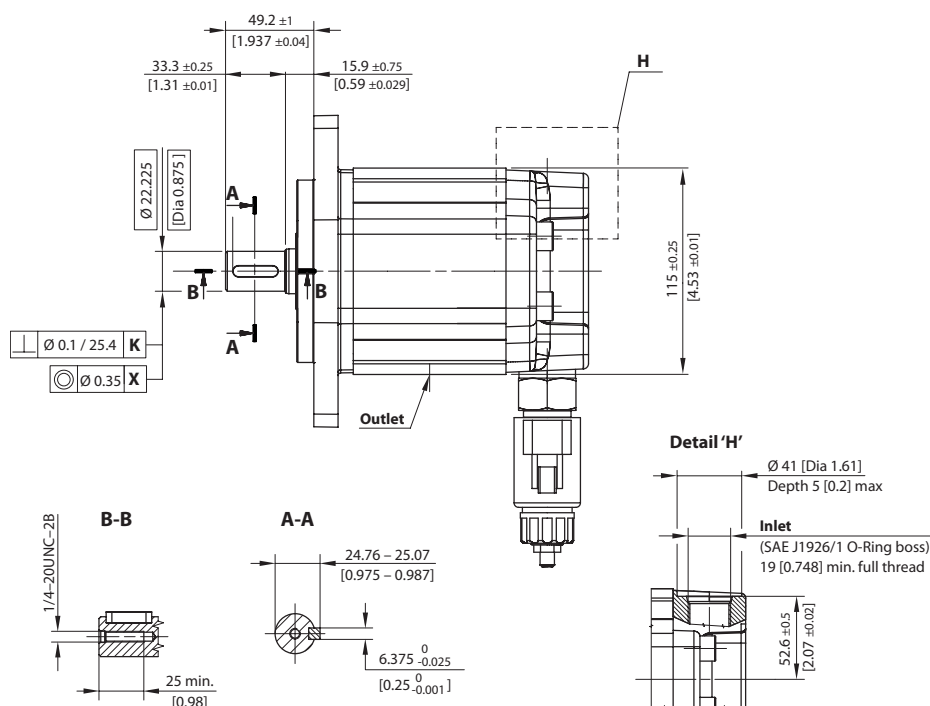

mm
[in]

SGM3Y – 07GB dimensions

Frame size	022	026	033	038	044
A	63 [2.48]	64.5 [2.54]	67 [2.64]	68.8 [2.71]	71 [2.8]
B	127.1 [5.04]	130.1 [5.12]	135.1 [5.32]	138.6 [5.46]	143.1 [5.63]
C	150.1 [5.91]	153.1 [6.03]	158.1 [6.22]	161.6 [6.36]	166.1 [6.54]
Inlet/Outlet	1-1/16-12UN-2B (SAE J1925/1, O-Ring boss); 19 [0.748] min. full thread				
Drain port	9/16-18UNF-2B (SAE J1925/1, O-Ring boss); 12.7 [0.5] min. full threads				

Model code example and maximum shaft torque

Flange/drive gear	Model code example	Maximum shaft torque
07GB	SGM3YN/022RA07GBY6NNE6NNNN/XNNNN	230 N·m [2036 lb·in]

For further details on ordering, see [Model Code](#), pages 64 - 67.



GROUP 3 FAN DRIVE GEAR MOTORS SGM3VC

Motor design

SGM3VC is Group 3 fan drive motor with integrated DCV valve for “reverse function”, anti-shock and proportional relief valve. Inlet/outlet and radial drain line are on cast iron rear cover.

Displacement range from 22.1 cm³/rev up to 44.1 cm³/rev [from 1.34 in³/rev up to 2.69 in³/rev].

Configurations include European and SAE flanges; taper 1:8, taper 1:5 and parallel Ø15.875 mm [Dia 0,62 in] shafts.

Outrigger bearing available as SAE A flange with taper shaft 1:8 and European flange with taper shaft 1:5.

SGM3VC

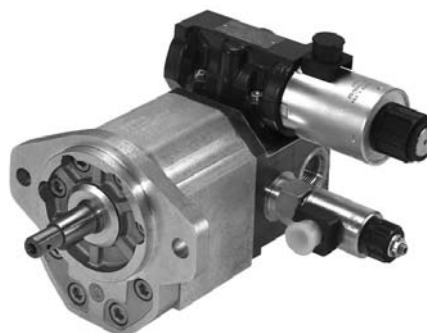

Technical data

Technical data for SGM3VC standard fan drive gear motors

Frame size		022	026	033	038	044
Displacement	cm ³ /rev [in ³ /rev]	22.1 [1.34]	26.2 [1.60]	33.1 [2.02]	37.9 [2.31]	44.1 [2.69]
Peak pressure	bar [psi]	270 [3916]	270 [3916]	270 [3916]	270 [3916]	270 [3916]
Rated pressure		250 [3626]	250 [3626]	250 [3626]	250 [3626]	250 [3626]
Back pressure		150 [2176]	150 [2176]	150 [2176]	150 [2176]	150 [2176]
Maximum speed	min ⁻¹ (rpm)	2500	2500	2500	2500	2300
Minimum speed		800	800	800	800	800
Weight	kg [lb]	16.32 [35.80]	16.42 [36.20]	16.52 [36.42]	16.62 [36.64]	16.72 [36.86]
Moment of inertia of rotating components	x 10 ⁻⁶ kg·m ² [x 10 ⁻⁶ lbf·ft ²]	198 [4699]	216 [5126]	246 [5838]	267.2 [6341]	294.2 [6981]



Electro proportional relief valve standard and D03 directional valve

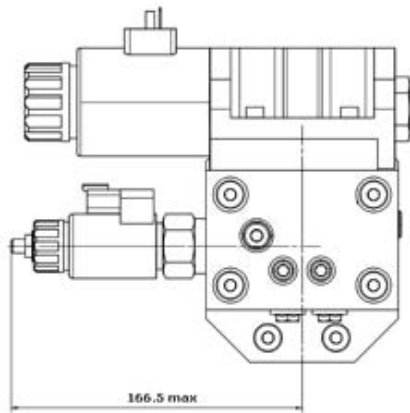

Electrical connectors	Deutsch DT 04-2P connectors (Protection rate IP 69K DIN 40050)
Electrical supply to EH valve	0 to 1.1 A @ 12 V DC, with coil resistance of 7.2 Ω @ 20 °C [68 °F] 0 to 0.55 A @ 24 V DC, with coil resistance of 28.8 Ω @ 20 °C [68 °F]
Directional valve coil	12 - 24 V DC
PWM frequency	from 100 to 200 Hz

Electro proportional relief valve flat curve and D03 directional valve

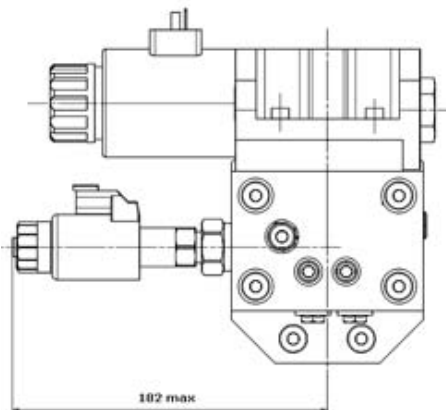

Electrical connectors	Deutsch DT 04-2P connectors (Protection rate IP 69K DIN 40050)
Electrical supply to EH valve	0 to 1.1 A @ 12 V DC, with coil resistance of 6.4 Ω @ 20 °C [68 °F] 0 to 0.55 A @ 24 V DC, with coil resistance of 26.2 Ω @ 20 °C [68 °F]
Directional valve coil	12 - 24 V DC
PWM frequency	from 100 to 250 Hz



Product code

Model code

A	B	C	D	E	F	G	H	I	J	K	L	M	N	O
□□□□□□□□	□□□□	□	□	□□	□□	□□	□□	□□	□□	□	□	□□□□	□	□

A Family

SGM3VC Gr3 Reversible Fan Drive Motor with Proportional Pressure Valve

B Displacement

022	22,1 cc	038	37,9 cc
026	26,2 cc	044	44,1 cc
033	33,1 cc		

C Rotation

L	Left rotation
R	Right rotation

D Project version

A	High Temperature sealing Dust protector Rust protected screws
----------	---------------------------------------------------------------------

E Mounting flange

01	European 01 flange, Pilot Ø50,8+4 holes (98,4x128,1)	
-----------	------------------------------------------------------------	--

07	SAE B-flange pilot Ø101,6 +2 holes	
-----------	---------------------------------------	--

91	Outrigger bearing flange 01 Taper 1:8 M14x1,5 key 4x7,5	

9Y	Outrigger Bearing with dust cover - SAE B flange pilot Ø101,6 [Dia 4 in] 2-bolts 1:8 Tapered shaft thread 5/8-18UNF, Key 6,375mm [0.25 in]	

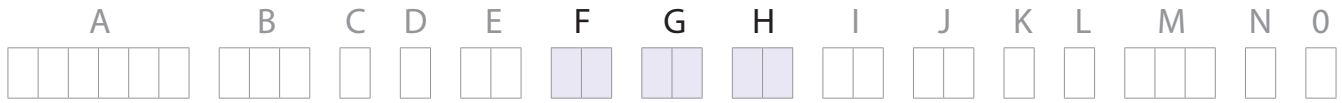

F Drive gear

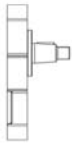
BA	Taper 1:8-M14x1,5 Key 4 (for Mounting Flange 01+Outrigger Bearing 91) Special	
-----------	-------------------------------------------------------------------------------------	-----------------------------------------------------------------------------------

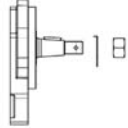
BP	Taper 1:8-5/8-18UNF-2A Key 6,375 with NUT & WASHER (for SAE B flange) Special	
-----------	-------------------------------------------------------------------------------------	-------------------------------------------------------------------------------------

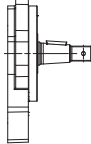
BC	Taper 1:8-5/8-18UNF-2A Key 6,375	
-----------	-------------------------------------	------------------------------------------------------------------------------------

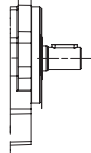
GB	Parallel Ø22,225xL25,4 Key 6,375x6,375x25,4+thd hole:1/4-20UNC-2B	
-----------	-------------------------------------------------------------------------	--------------------------------------------------------------------------------------

G Rear cover

RA	Proportional PRV Reversing Valve Cover, 12 V DCV03 Deutsch connector, Anti-Shock-MakeUp Valve, 1-1/16 12UN Work Ports, 9/16-18UNF Radial Drain Port
RB	Proportional PRV Reversing Valve Cover, 24 V DCV03 Deutsch connector, Anti-Shock-MakeUp Valve, 1-1/16 12UN Work Ports, 9/16-18UNF Radial Drain Port

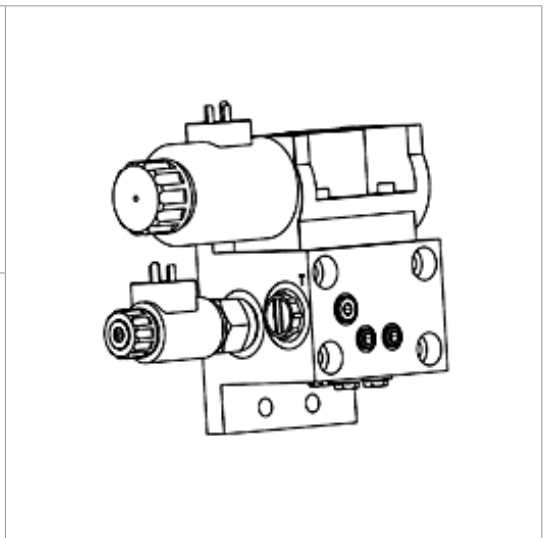

H Inlet port

NN	No inlet on body
-----------	------------------



A	B	C	D	E	F	G	H	I	J	K	L	M	N	O
<input type="checkbox"/>	<input type="checkbox"/>	<input type="checkbox"/>	<input type="checkbox"/>	<input type="checkbox"/>	<input type="checkbox"/>	<input type="checkbox"/>	<input type="checkbox"/>	<input checked="" type="checkbox"/>	<input checked="" type="checkbox"/>	<input checked="" type="checkbox"/>	<input checked="" type="checkbox"/>	<input type="checkbox"/>	<input type="checkbox"/>	<input type="checkbox"/>

I Outlet port

NN No outlet on body

J Ports Pos & Spec Body

NN Std from catalogue

K Seals

N Standard high temperature seals

L Screws

N Standard Rust protected screws



A	B	C	D	E	F	G	H	I	J	K	L	M	N	O

M Set valves

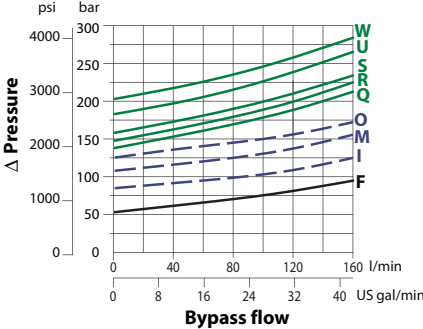
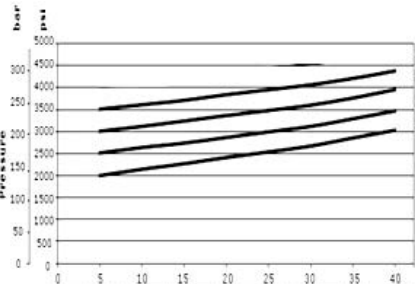
XNN	No valve
XA*	Standard relief valve with coil voltage 12 V DC, DT connector
XB*	Standard relief valve with coil voltage 24 V DC, DT connector
X*F X*I X*M X*O X*Q X*R X*S X*U X*W	 <p>Select Pressure vs. Bypass flow requirements using the graph.</p> <p>Three color curves represent three types of valves.</p> <p>Each valve is characterized by different nominal spring ranges.</p>
SA*	Flat curve valve with coil voltage 12 V DC, DT connector
SB*	Flat curve valve with coil voltage 24 V DC, DT connector
S*O S*S S*W S*X	 <p>Select Pressure vs. Bypass flow requirements using the graph.</p> <p>Each valve is characterized by different nominal spring ranges.</p>

N Type of mark

N	Standard marking
A	Standard + customer code
Z	Without marking
*	Special customer marking

O Mark position

N	Std Marking position (on top)
A	Special Marking position on the bottom



SGM3VC • 07BC dimensions

mm
[in]

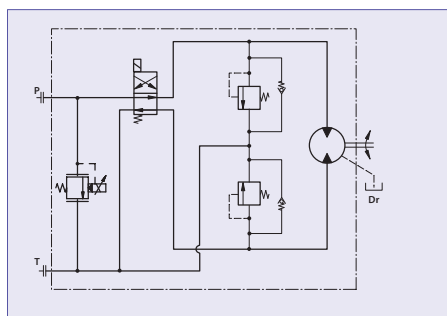
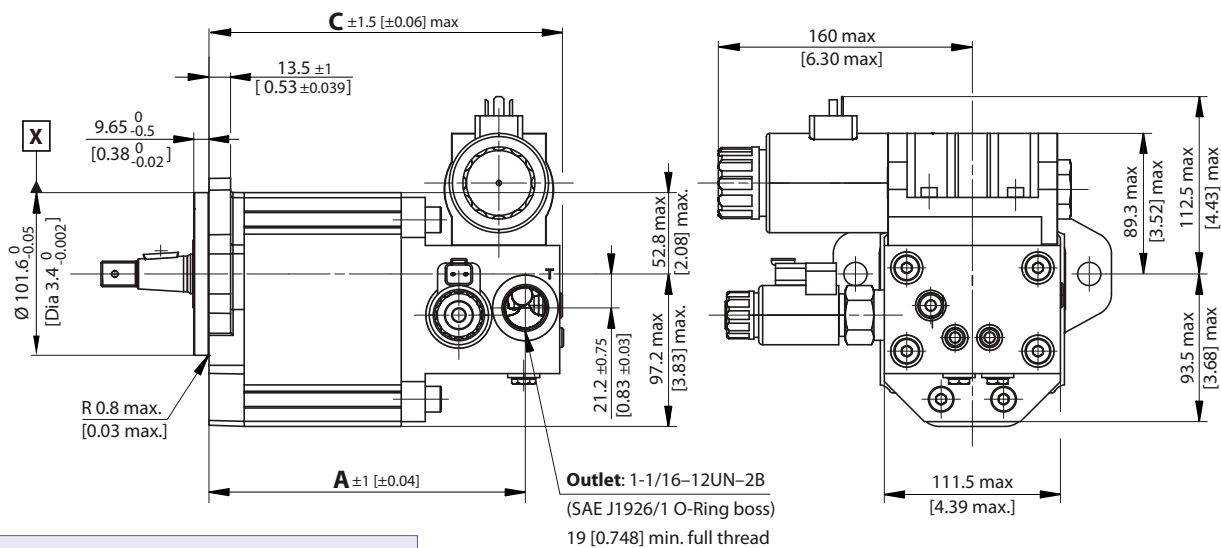
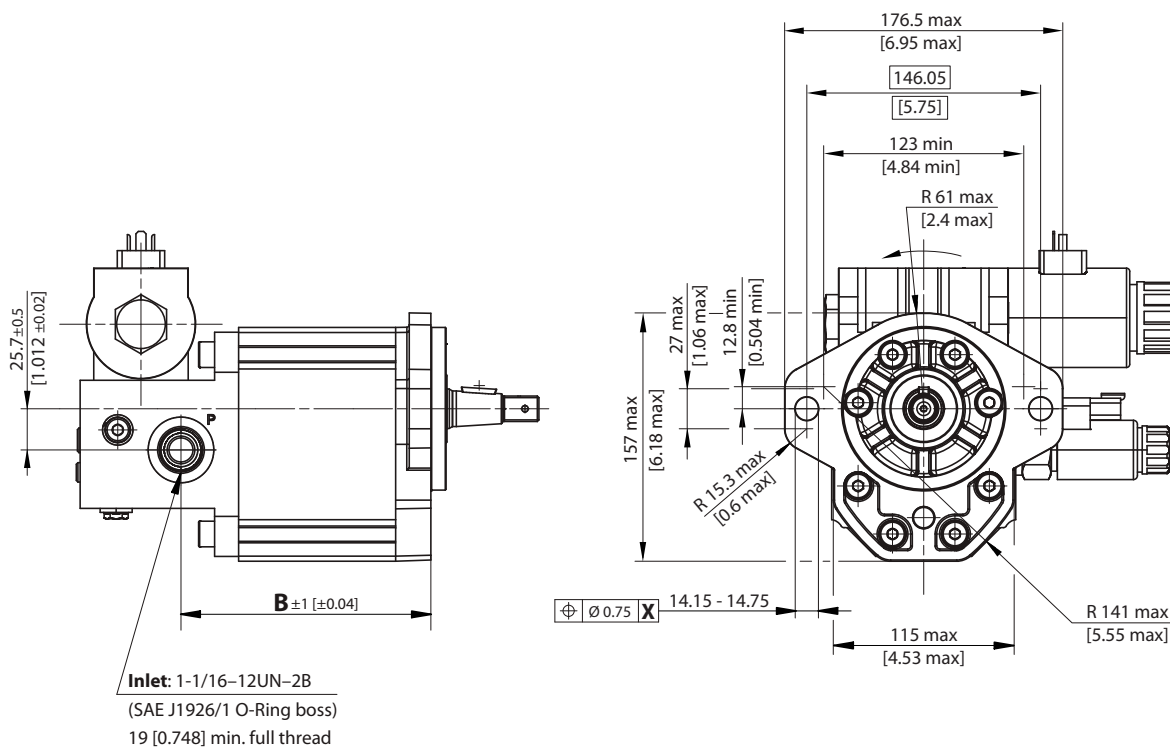



mm
[in]

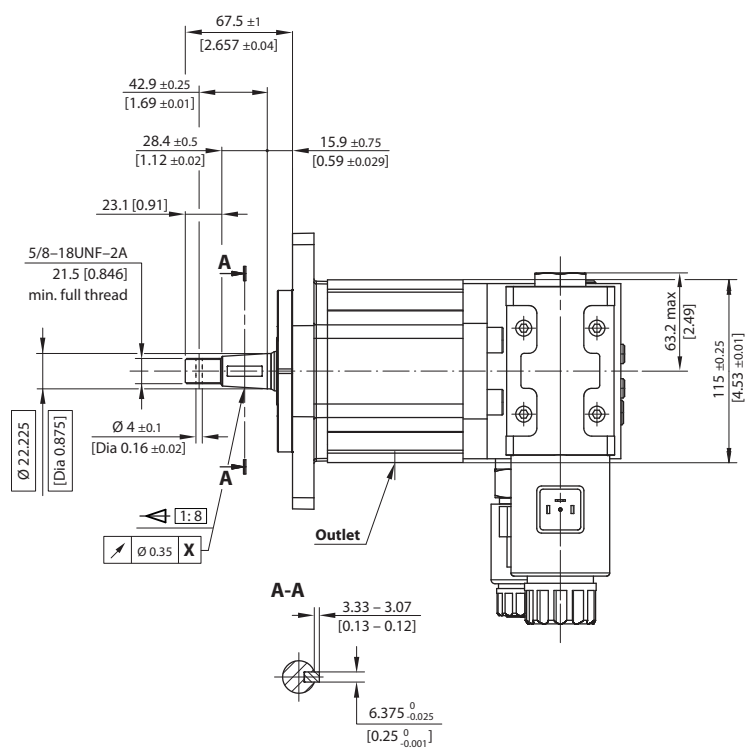

SGM3VC – 07BC dimensions

Frame size	022	026	033	038	044
A (inlet)	181.6 [7.15]	184.6 [7.27]	189.6 [7.46]	193.1 [7.62]	197.6 [7.78]
B (inlet)	140.1 [5.52]	143.1 [5.63]	148.1 [5.83]	151.1 [5.95]	156.1 [6.15]
C (overall)	204.8 [8.06]	207.8 [8.18]	212.8 [8.38]	216.3 [8.52]	220.1 [8.67]
D (drain)	149.1 [5.87]	152.1 [5.99]	157.1 [6.19]	160.6 [6.32]	165.1 [6.50]
Inlet/Outlet	1-1/16-12UN-2B (SAE J1925/1, O-Ring boss); 19 [0.748] min. full thread				
Drain port	9/16-18UNF-2B (SAE J1925/1, O-Ring boss); 12.7 [0.5] min. full threads				

Model code example and maximum shaft torque

Flange/drive gear	Model code example	Maximum shaft torque
07BC	SGM3VC/033LA07BCYENNE6NNNN/XNNNN	230 N•m [2036 lb•in]

For further details on ordering, see [Model Code](#), page 74 - 77.



SGM3VC • 07GB dimensions

mm
[in]

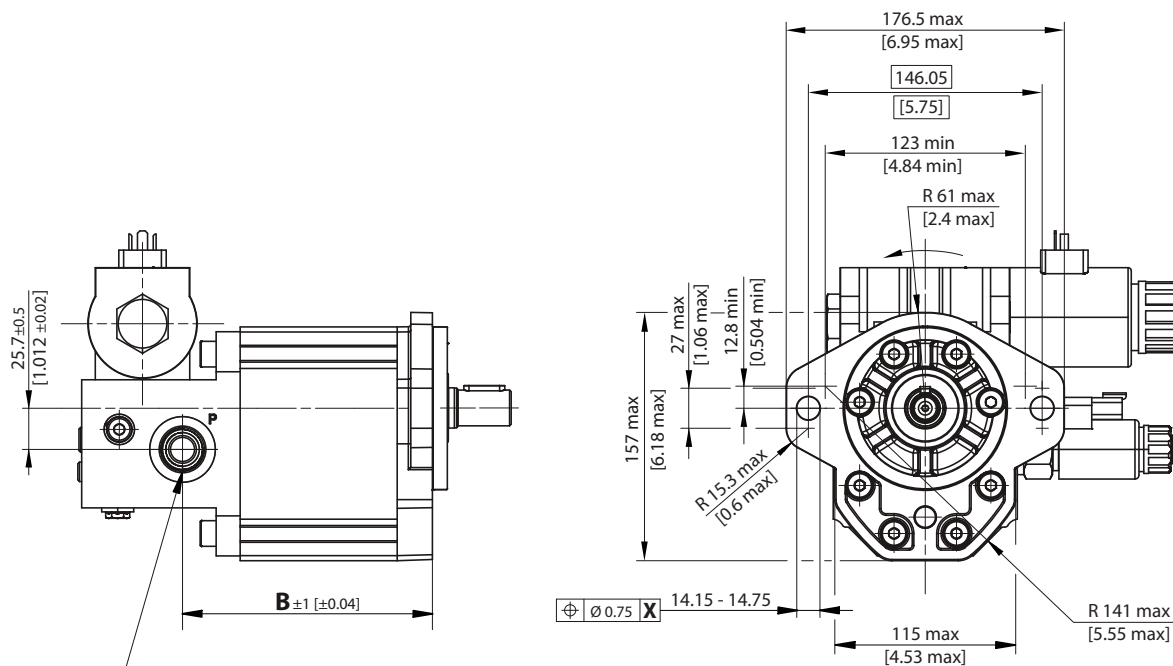

Inlet: 1-1/16-12UN-2B
(SAE J1926/1 O-Ring boss)
19 [0.748] min. full thread

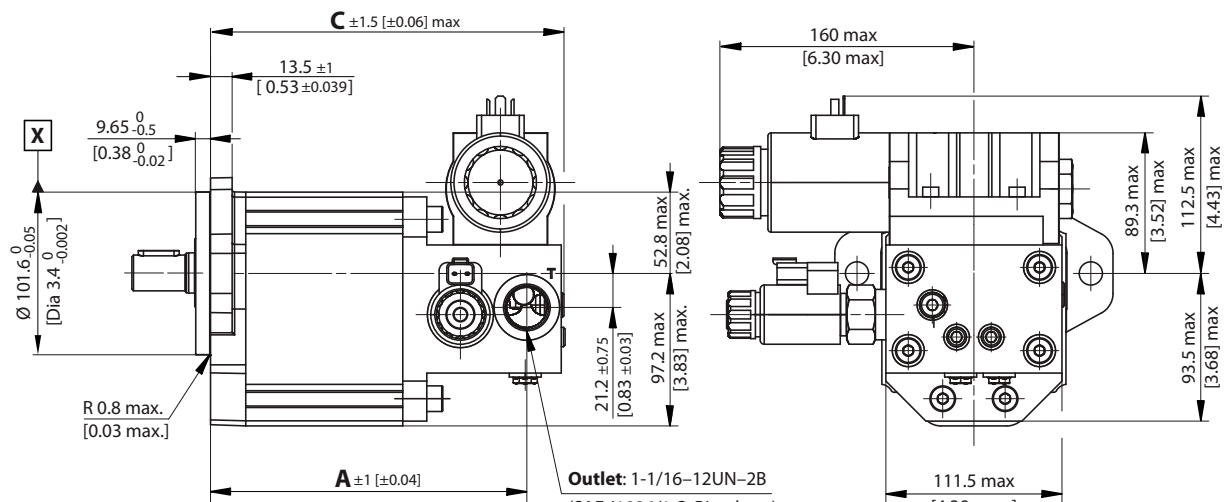

Outlet: 1-1/16-12UN-2B
(SAE J1926/1 O-Ring boss)
19 [0.748] min. full thread

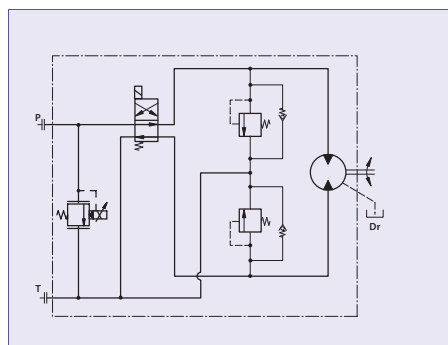

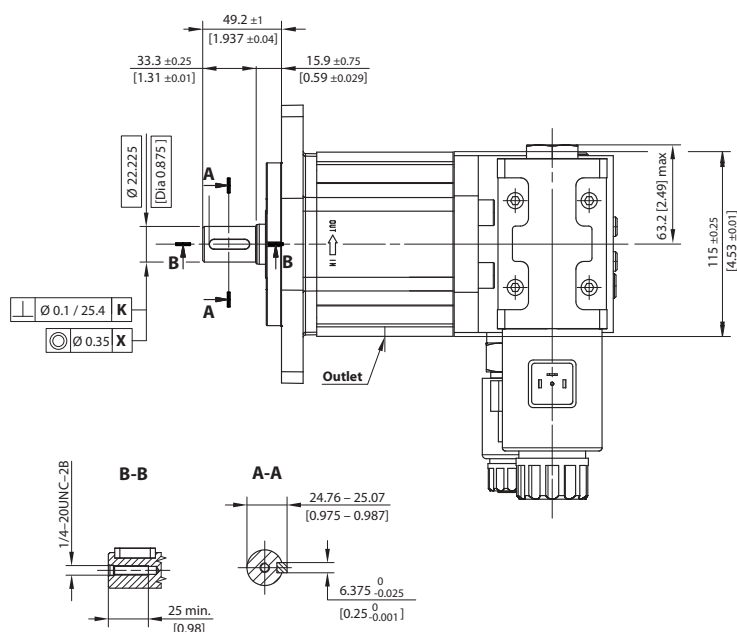

mm
[in]

SGM3VC – 07GB dimensions

Frame size	022	026	033	038	044
A (inlet)	181.6 [7.15]	184.6 [7.27]	189.6 [7.46]	193.1 [7.62]	197.6 [7.78]
B (inlet)	140.1 [5.52]	143.1 [5.63]	148.1 [5.83]	151.1 [5.95]	156.1 [6.15]
C (overall)	204.8 [8.06]	207.8 [8.18]	212.8 [8.38]	216.3 [8.52]	220.1 [8.67]
D (drain)	149.1 [5.87]	152.1 [5.99]	157.1 [6.19]	160.6 [6.32]	165.1 [6.50]
Inlet/Outlet	1-1/16-12UN-2B (SAE J1925/1, O-Ring boss); 19 [0.748] min. full thread				
Drain port	9/16-18UNF-2B (SAE J1925/1, O-Ring boss); 12.7 [0.5] min. full threads				

Model code example and maximum shaft torque

Flange/drive gear	Model code example	Maximum shaft torque
07GB	SGM3VC/022RA07GBY6NNE6N>NNN/X>NNNN	230 N•m [2036 lb•in]

For further details on ordering, see [Model Code](#), page 74 - 77.



Outrigger bearing

SGM3NC and SGM3YN dimensions

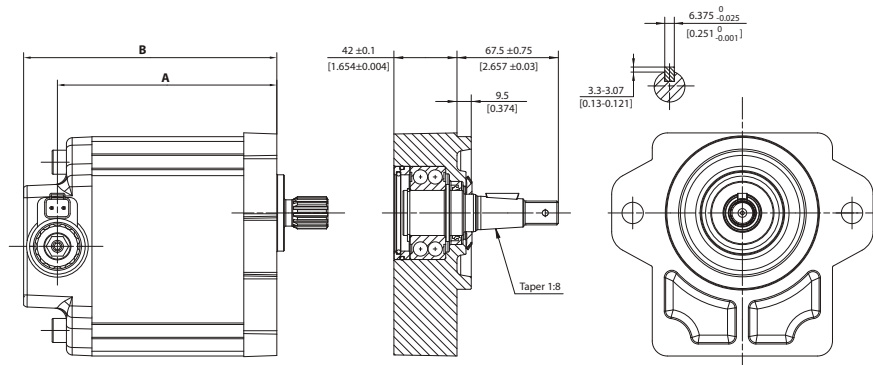

Frame size		022	026	033	038	044
Dimension	A	127.1 [5.04]	130.1 [5.12]	135.1 [5.32]	138.6 [5.46]	143.1 [5.63]
	B	150.1 [5.91]	153.1 [6.03]	158.1 [6.22]	161.6 [6.36]	166.1 [6.54]

SGM3VC dimensions

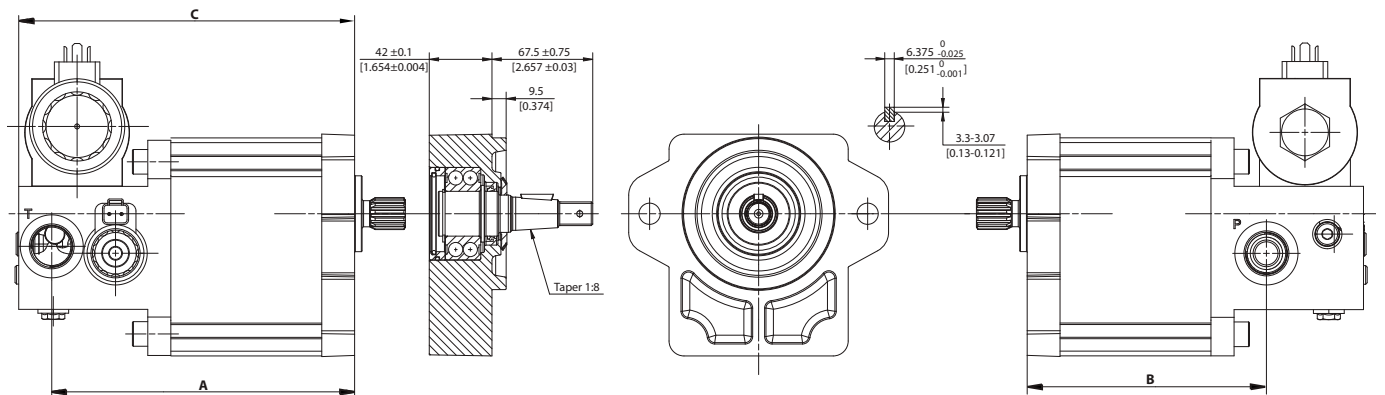

Frame size		022	026	033	038	044
Dimension	A (inlet)	181.6 [7.15]	184.6 [7.27]	189.6 [7.46]	193.1 [7.60]	197.6 [7.78]
	B (outlet)	140.1 [5.52]	143.1 [5.63]	148.1 [5.83]	151.1 [5.95]	156.1 [6.15]
	C (overall)	204.8 [8.06]	207.8 [8.18]	212.8 [8.38]	216.3 [8.52]	220.1 [8.67]



Notes

Italy

Via Villanova 28
40055 Villanova di Castenaso
Bologna, Italia
Telephone: +39 051 6054 411

U.S.A.

2800 East 13th Street
Ames, IA 50010, USA
Phone: +1 515 239 6677
Fax: +1 515 239 6618

Slovakia

Kukučínova 2148-84
01701 Považská Bystrica, Slovakia
Phone: +421 424 301 202
Fax: +421 424 301 626

E-mail: turollaocg@turollaocg.com
www.turollaocg.com

Local address

